



Everlux[®]

Photoluminescent maritime safety signs

Introduction

Technical properties of photoluminescent safety signs

Quality, Standards & Certification:

- Ⓢ Everlux® photoluminescent products are manufactured to the highest technical standards using state of the art equipment; thus ensuring we offer the best available photoluminescent quality for safety signs.
- Ⓢ Everlux® photoluminescent safety signs comply with IMO Resolutions, Solas Convention and ISO Standards.
- Ⓢ Everlux® products have Type Approval by Lloyd's Register and are MED certified by DNV.

Technical Properties:

Luminance properties			
Applicable Standards and Resolutions/ product	Luminescent intensity (mcd/m ²) (After removing the exciting light)		Period of light decay Luminance Intensity greater than a 0.3 mcd/ m ²
	10 minutes	60 minutes	
IMO Res. A.752(18)	15 mcd/m ²	2 mcd/m ²	...
ISO 15370	15 mcd/m ²	2 mcd/m ²	...
Ⓢ Everlux® (a)	100 mcd/m ²	10 mcd/m ²	1200 minutes
Ⓢ Everlux® (b)	40 mcd/m ²	8 mcd/m ²	1800 minutes

a) According to DIN 67510 measurement protocol;
b) According to ISO 15370 measurement protocol.

- Photoluminescent signs:** Photoluminescent rigid plastic 1.2 ± 0.1mm thickness and self-adhesive photoluminescent vinyl.
- Printing:** Serigraphy, high quality gloss paint with UV resistance and an indoor durability in excess of 5 years.
- Fire resistance:** Flame retardant according to IEC 60092-101: 2018 and IMO FTPC Part 5 (IMO Res. MSC.307(88)).
- Surface:** Antistatic and easy to clean.
- Chemical characteristics:** Non-radioactive, non-phosphorous, lead-free and non-poisonous.

Safety signage is a language comprised of pictorial graphics, shapes and colors.



Color should be for everyone!

... and because colors are determinant in safety signs, Ⓢ Everlux® has associated with ColorAdd - the color identification system for colorblind people.

ColorAdd is a project which was developed with the goal of allowing colorblind people to correctly identify each color and therefore to contribute for their social integration whilst making communication more effective, responsible and inclusive. ColorAdd is an extremely intuitive symbolic language that uses the primary colors and their combination to create the entire colors/codes palette.

By including the ColorAdd system, the Ⓢ Everlux® catalogue allows colorblind people to fully comprehend all the components of safety signs.

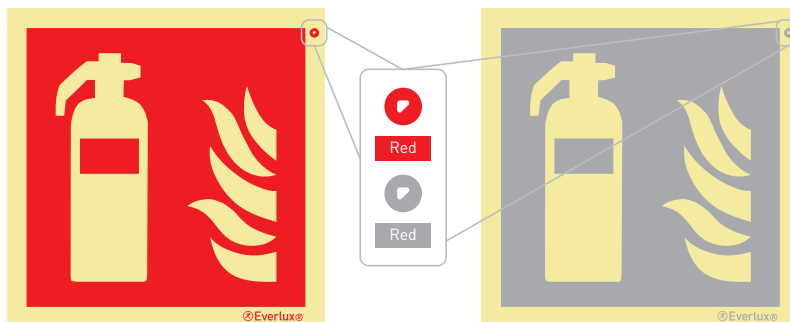

COLORS | SYMBOLS



WHITE | BLACK | GREY



GOLD | SILVER



























LIGHT TONES



DARK TONES



Index

	How to order.....	03
	Market assurance and certification.....	04
	Mounting options.....	05
	Viewing distances.....	06-08
	Life-saving appliances.....	09-12
	Escape route signs.....	13-16
	IMO fire control signs.....	17-23
	Fire fighting equipment signs.....	24-32
	ⓈEverlux® Low Location Lighting system.....	33-41
	Panoramic signs.....	42
	Marking strips.....	43
	Warning signs.....	44-46
	Mandatory signs.....	47-51
	Prohibition signs.....	52-55
	Multipurpose combination signs.....	56-57
	Information signs.....	58
	ISPS Code signs.....	59-60
	Safety signs for super yachts.....	61-62
	Offshore wind - safety signs.....	63-65
	Water safety signs.....	66-67
	Temporary tie tags.....	68
	Anti-splashing tape.....	69
	Pipe content identification.....	70-72
	IMDG Code.....	73-74
	Safety awareness and training procedures.....	75-95
	General safety awareness notices.....	96
	Safety plans.....	97
	Fire control and safety plans.....	98
	Bespoke signage solutions.....	99
	ⓈEverlux® frames.....	100
	ⓈEverlux® adhesive.....	100
	IMPA and ISSA cross reference guide.....	101-106
	Standards and regulations.....	107

How to order

All ⓈEverlux® and ⓈEverlux®-LLL signs have a unique 5 digit code.

To order you need to indicate the following:

- 1.The product code;
- 2.The size (mm);
- 3.The type of sign (see page 5). If not indicated we will supply Type 1;
- 4.The material of the sign. Most of the ⓈEverlux® signs are available in photoluminescent rigid plastic (F) and photoluminescent self-adhesive vinyl (Z). There are several product ranges with different base materials. The complete list of sign base materials is: F - photoluminescent rigid plastic; Z - self-adhesive vinyl; O - white rigid plastic; V - white self-adhesive vinyl; VT - transparent self-adhesive vinyl PC - non-slip self-adhesive photoluminescent polycarbonate; T - aluminium composite; TA - transparent acrylic; FA - frosted acrylic; and SS - stainless steel.

(*)Example:

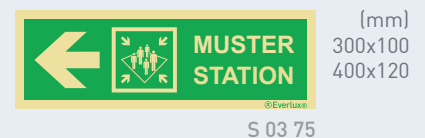

(*) The sign on this example is available in the following sizes 300x100 and 400x120; in Type 1, 2 or 3; and in photoluminescent rigid plastic and self-adhesive photoluminescent vinyl.

To order the above sign in 400x120, Type 1 and in photoluminescent rigid plastic you order: S 03 75 – 400x120 – Type 1 - F.

It is also possible to order by IMPA or ISSA codes. Please refer to the cross reference guide on pages 97 – 102 to find the equivalent

ⓈEverlux® item code.

Introduction

Sign performance and technical properties

Technical guarantees for the market

The photoluminescent properties and performance values are printed on all Everlux® signs as per ISO and DIN Standards requirements. This provides consumers with the correct information and a guarantee of high quality. Please see the following example:

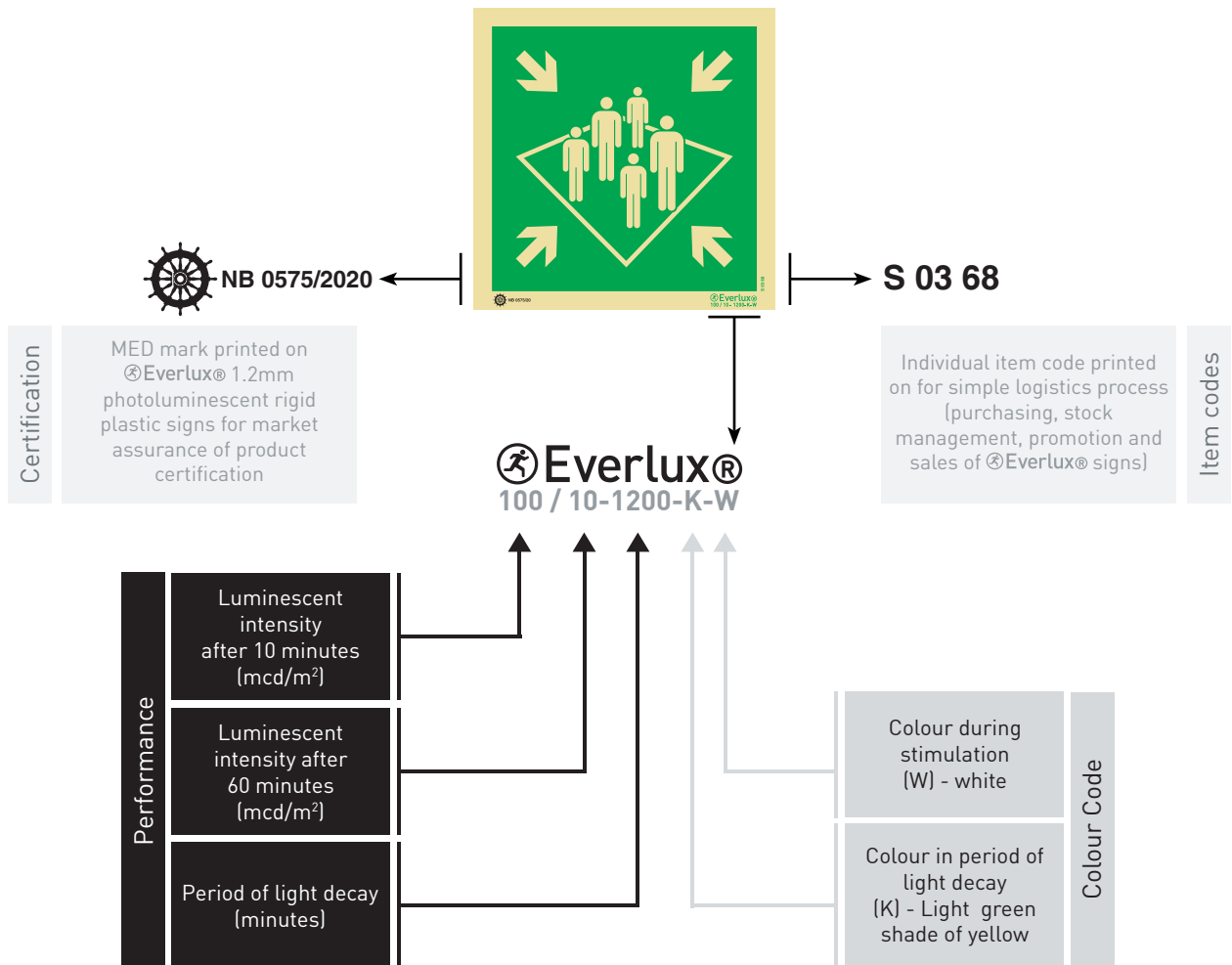

This brings the signs into alignment with other safety equipment where technical information is provided on the apparatus, e.g. extinguishers.

On all Everlux® photoluminescent safety signs the technical properties are printed and illustrate their performance as per ISO and DIN Standards requirements. This helps specifiers and consumers to make informed decisions about the signs to be used.

The quality of Everlux® safety signs is ensured by maintaining a continuous quality control system. All Everlux® photoluminescent products have the Lloyd's Register Type Approval Certificate



and are certified by DNV according to MED.

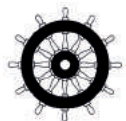

Notified Body n° 0575

The method of measuring the luminance performance according to ISO and DIN Standards is carried out in the laboratory, where all measuring equipment is calibrated by an accredited and independent official entity.

Different types of application - various alternatives for mounting signs

For an adequate use of signs they must be mounted according to the appropriate viewing angle.

Type 1 (single-sided)

Parallel wall mounted sign.

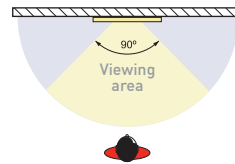
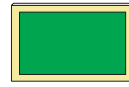

Type 2 (double-sided)

The signs are mounted perpendicularly to the wall by means of a flexible bracket. The bracket consists of a strip that enables the installation of double-sided signs in any location and was developed with the aim of allowing the sign to swing through 180° (+90° and -90°) without breaking.

Note: The bracket is always mounted to the left hand side of the sign, i.e.: Picture 1 - code S 04 21 Type 2; and in Picture 2 - code S 04 26 Type 2.

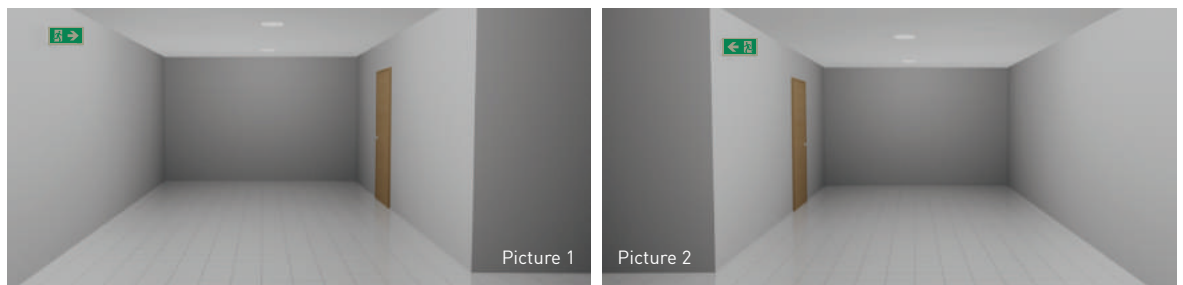
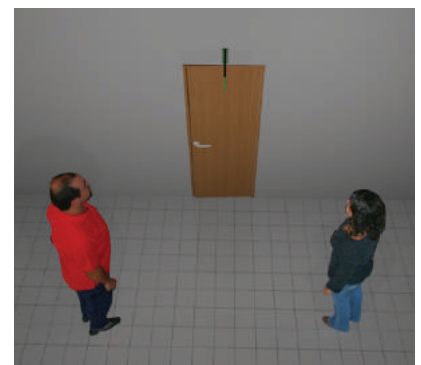
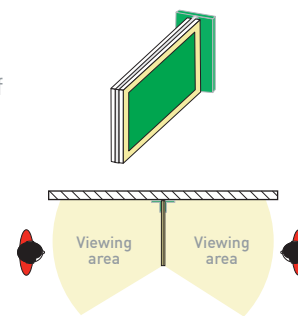

Type 3 (double-sided)

A Type 3 suspended double-sided sign is to be hung from the ceiling. The sign is supplied with holes drilled in the top corners which allow the appropriate fixings to be used (fixings not supplied).

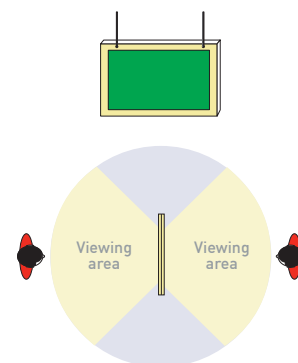

Type P (panoramic signs)

The sign with the greatest visibility. These signs are printed on both exterior surfaces and guarantee a viewing angle of 180°.

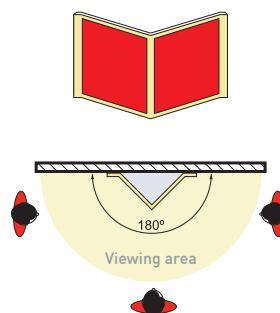

Introduction

Sizes and viewing distances

The size of the sign is defined by the maximum viewing distance from which the sign is understandable. According to ISO 3864-1:2011, the viewing distance at which a sign of a particular size is conspicuous and comprehensible depends on the illumination of the sign.

$$l = z_0 \times h$$

Where: l - is the observation distance (m);
 z_0 - is the distance factor;
 h - is the height of the sign (m).

Life-saving and emergency equipment, escape route and fire fighting equipment signs

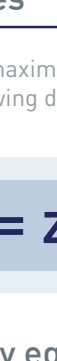
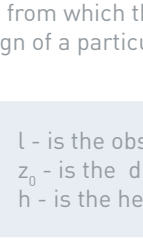
Geometric Shape	Meaning	 Everlux [®] sign sizes (mm)	h height of the sign (mm)	l observation distance (m)
	(z ₀ =60)	100x100	80	5
		150x150	131	8
		200x200	180	11
		300x300	278	17
		400x400	376	23
 Escape Route and Fire Fighting Equipment Signs (z ₀ =60)		150x50	36	2
		150x75	55	3
		200x50	36	2
		200x70	55	3
		200x100	80	5
		300x70	57	3
		300x100	80	5
		300x150	129	8
		400x100	78	5
		400x120	98	6
		400x150	129	8
		400x200	180	11
		450x150	129	8
		600x150	129	8
		600x200	180	11
		600x300	276	17
		150x200 (*)	129	8
200x300 (*)	180	11		
300x400 (*)	276	17		

(*) Signs with complementary text for which only the height of the pictogram is relevant for the calculation of their observation distance

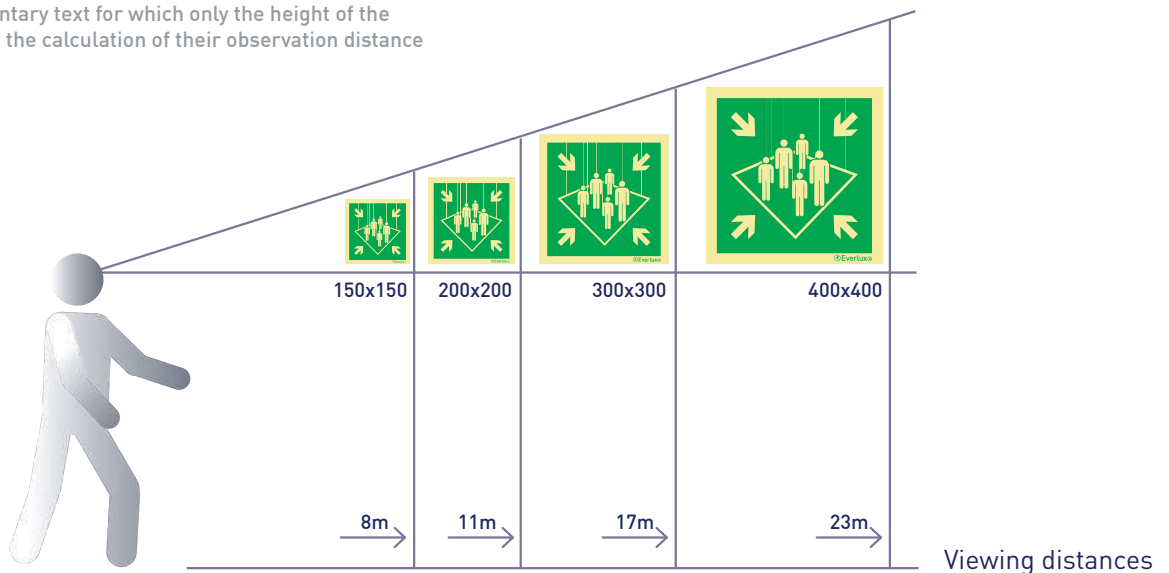

Life-saving and emergency equipment, escape route and fire fighting equipment signs

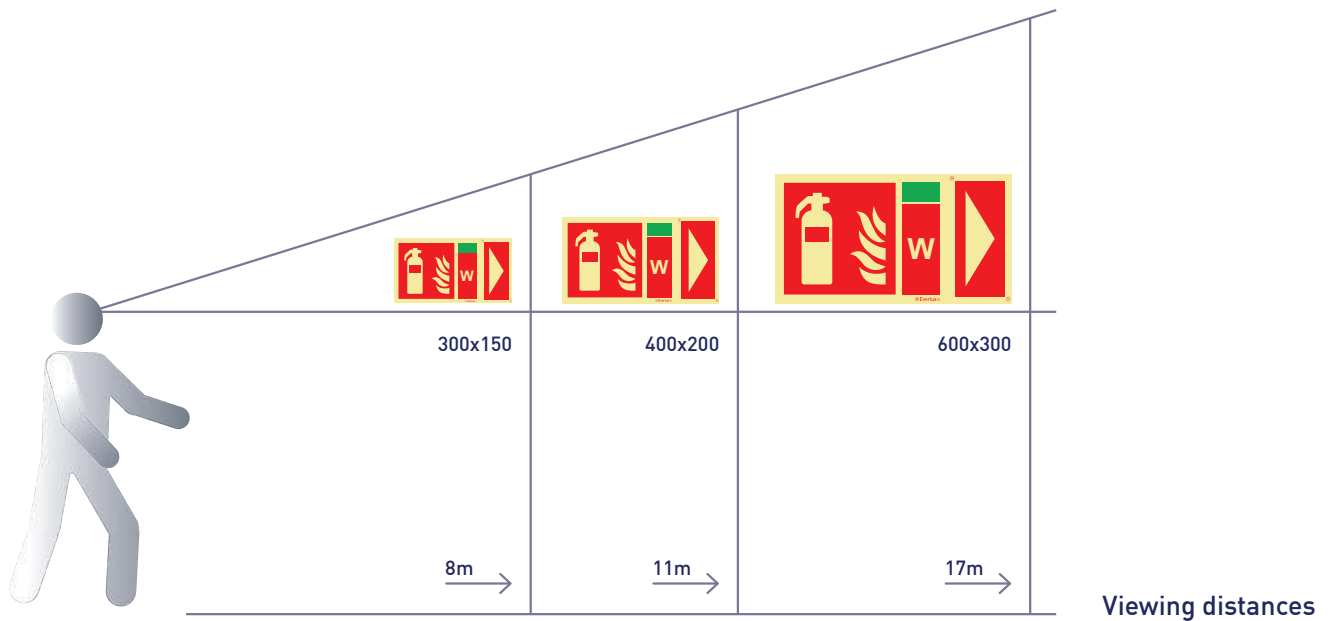

Exception signs

Geometric Shape	Meaning	Everlux® sign sizes (mm)	h height of the sign (mm)	l observation distance (m)
	$z_0=95$ for S 04 61 and S 04 62 signs as per ISO 7010:2019	150x150	129	12
		200x200	180	17
		300x300	278	26
		400x400	376	36

Note: The distance factor (z_0) is assumed as a general value of 60 as defined by ISO 3864-1:2011. For ISO 7010 - S 04 61 and S 04 62 emergency exit signs the recommended value of z_0 is 95 considering an illuminance range between 5 and 100 lux. Over the illuminance range up to about 100 lux, z_0 increases according to ISO 3864-1:2011.

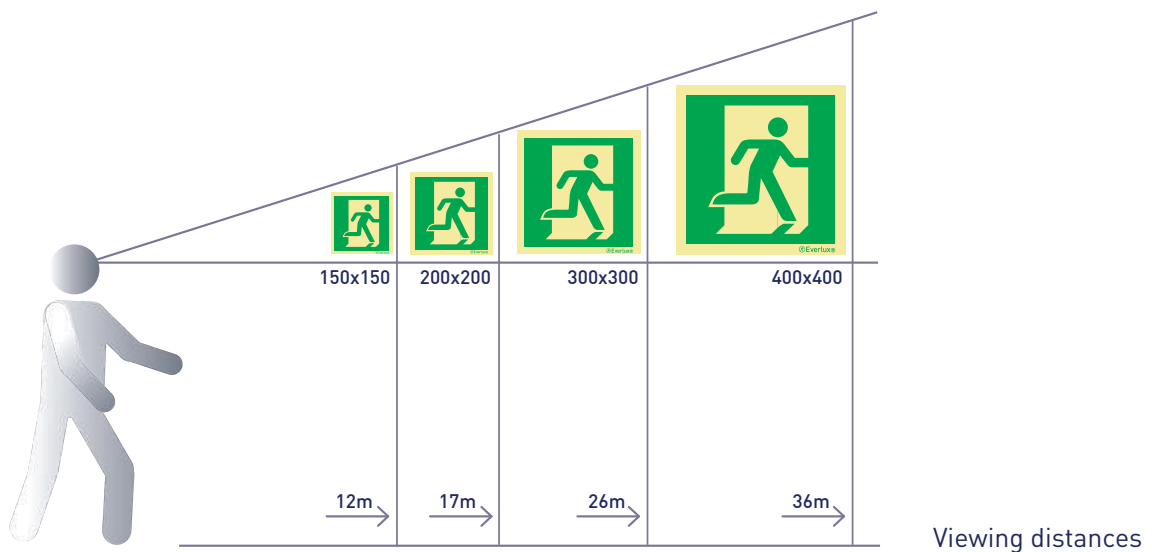

Introduction

Mandatory and prohibition action signs

Geometric Shape	Meaning	Everlux [®] sign sizes (mm)	h height of the sign (mm)	l observation distance (m)
	Prohibition and Mandatory Action Signs (z ₀ =60)	100x100	80	5
		150x150	131	8
		200x200	180	11
		300x100	80	5
		300x300	278	17
		400x150	131	8
400x400	376	23		

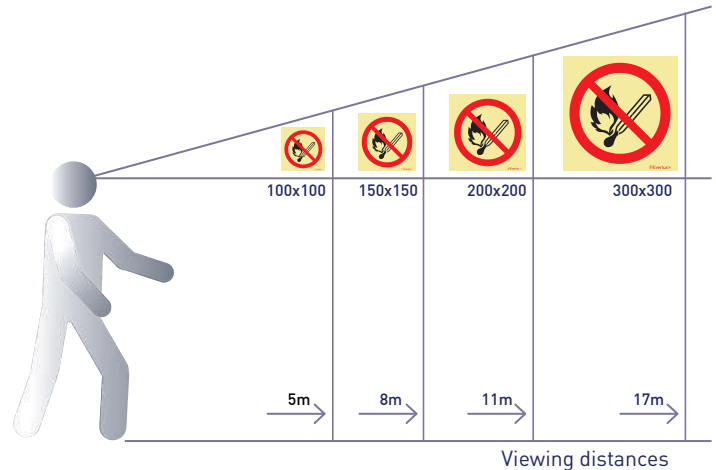

Hazard signs

Geometric Shape	Meaning	Everlux [®] sign sizes (mm)	h height of the sign (mm)	l observation distance (m)
	Hazard Signs (z ₀ =60)	base 100	56	3
		base 150	94	6
		base 200	130	8
		base 300	193	12
		base 400	264	16
		300x100	80	5
		400x150	113	7

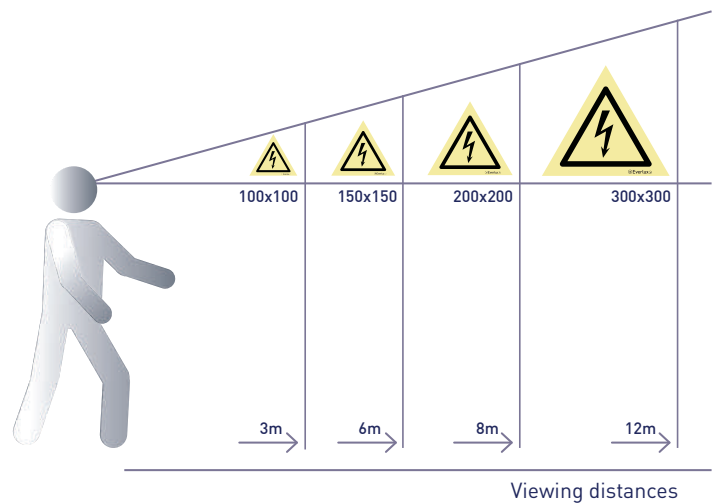

IMO Resolution A.1116(30), adopted on 5 December 2017 – Escape Route Signs and Equipment Location Markings.

In sequence to the 2016 IMO MSC.1/Circ.1553 Shipboard escape route signs and emergency equipment location markings which invited Contracting Governments to start implementing safety signs as per ISO 24409-2:2014 on a voluntary basis, IMO Resolution A.1116(30) adopts these escape route signs and equipment location markings.

The adoption of ISO's symbols by IMO is a step forward to the needed standardization of the international symbols to indicate the location of emergency equipment to people who travel and work on-board ships and other marine installations.

IMO Resolution A.1116(30), adopted on 5 December 2017 – Escape Route Signs and Equipment Location Markings is effective for ships constructed on or after 1 January 2019 and for ships which undergo repairs, alterations, modifications and outfitting on or after that date.

The examples below illustrate some of the changes on safety signs that the adoption of IMO Resolution A.1116(30) entail:

Everlux[®] have been working on the inclusion of these signs as standard catalogue signs since the publication of ISO 24409-2:2014 Ships and marine technology – Design, location and use of shipboard safety signs, safety-related signs, notices and safety markings – Part 2: Catalogue.

IMO SYMBOL PRIOR TO IMO RES. A.1116(30) ADOPTION	IMO SYMBOL POST TO IMO RES. A.1116(30) ADOPTION

Life-saving appliance IMO signs - according to SOLAS Convention [Chap. III Reg. 9.2.3.] and ISO 24409

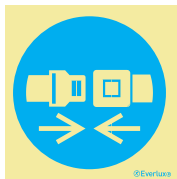

S 00 01

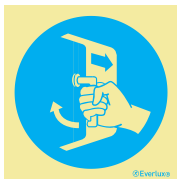

S 00 02

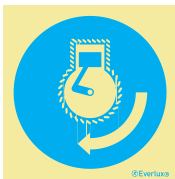

S 00 03

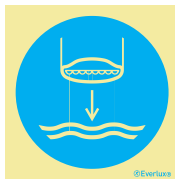

S 00 04

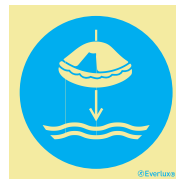

S 00 05



(mm)
150x150
200x200
300x300

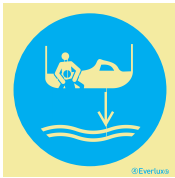

S 00 06

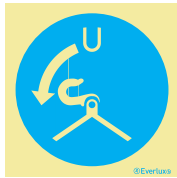

S 00 07

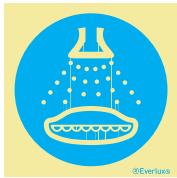

S 00 08

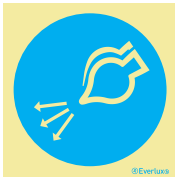

S 00 09

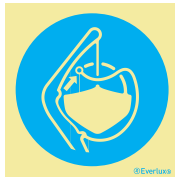

S 00 10

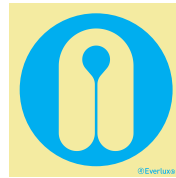

S 00 11



FASTEN SEAT BELTS

S 01 01

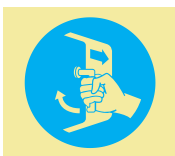

SECURE HATCHES

S 01 02



START ENGINE

S 01 03

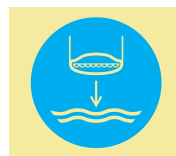

LOWER LIFEBOAT

S 01 04



(mm)
150x150
200x200
300x300



LOWER LIFERAFT

S 01 05

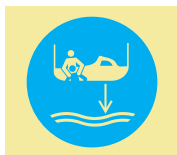

LOWER RESCUE BOAT

S 01 06

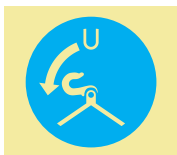

RELEASE FALLS

S 01 07

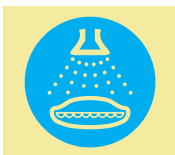

START WATER SPRAY

S 01 08

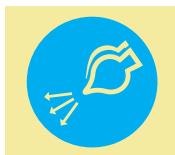

START AIR SPRAY

S 01 09

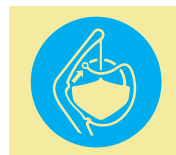

RELEASE GRIPES

S 01 10

Signs with symbols and supplementary text

Life-saving appliances

Life-saving appliance signs - according to IMO Resolution A.760 (18), ISO 17631 and ISO 24409











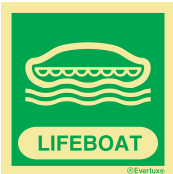





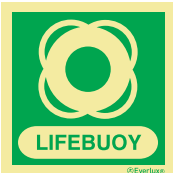



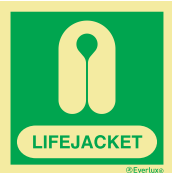

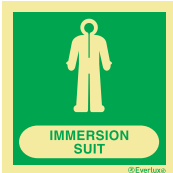









(mm)
150x150
200x200
300x300

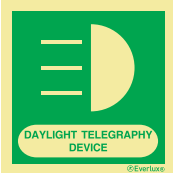







 S 02 01	 S 02 02	 S 02 03	 S 02 04		
 S 02 05	 S 02 06	 S 02 07	 S 02 08	 S 02 09	 S 02 10
 S 02 11	 S 02 12	 S 02 13	 S 02 14	 S 02 15	 S 02 16
 S 02 17	 S 02 18	 S 02 19	 S 02 20	 S 02 21	 S 02 22
 S 02 23	 S 02 24	 S 02 25	 S 02 26	 S 02 27	 S 02 28
 S 02 29	 S 02 30	 S 02 31	 S 02 32	 S 02 33	 S 14 67

Life-saving appliance signs - according to IMO Resolution A.760 (18), ISO 17631 and ISO 24409

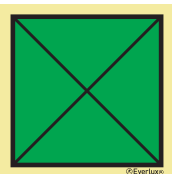
					 (mm) 150x150 200x200 300x300
S 02 51	S 02 52	S 02 53	S 02 54	S 02 55	
					
S 02 56	S 02 57	S 02 58	S 02 59	S 02 60	
					
S 02 62	S 02 63	S 02 64	S 02 65	S 02 66	
					
S 02 68	S 02 69	S 02 70	S 02 71	S 02 72	
					
S 02 74	S 02 75	S 02 76	S 02 77	S 02 78	
					
S 02 80	S 02 81	S 02 82	S 02 83	S 02 84	
					
S 02 79					
					
S 02 85					

Non-standard Life-saving appliance IMO signs

	 (mm) 150x150 200x200 300x300			
S 14 52				
				
S 14 62	S 14 64	S 14 65	S 14 66	S 14 65

Life-saving appliances

Emergency equipment signs

Emergency equipment must be installed on board and their location should be clearly signed for quick identification in case of need. For example, the automated external defibrillators (AED) are being increasingly used as means of assistance to victims of cardiac arrest. Several countries already provide that AED be used on board. The MCA - Maritime and Coastguard Agency - recommends that UK-flagged ships carry AED (MGN 297 (M)); whilst in Germany, the use of AED in some German-flagged ships is mandatory according to Ordinance for the Medical Care on Seagoing Vessels, issued by the BG for Transport and Traffic, and to Guideline No. 3, issued by the Sanitation Ship Committee of German Federal States.

Since the chance of survival for cardiac arrest victims significantly increases with a prompt response, the quick identification of AED equipment is vital. The identification of these equipments must be made using photoluminescent signs.

(mm)
150x150
200x200
300x300
400x400



S 03 00

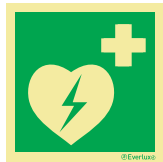

S 03 01

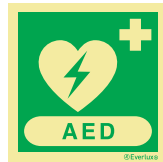

S 03 02

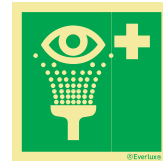

S 03 03

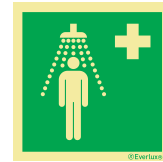

S 03 04

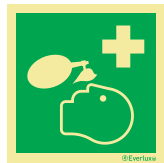

S 03 05

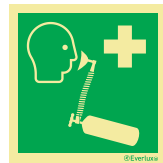

S 03 06



S 03 07

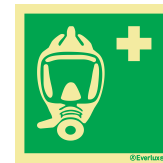

S 03 08

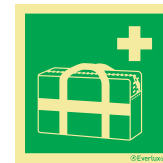

S 03 09



S 03 10



S 03 11



S 03 21

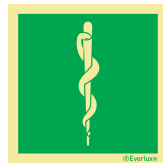

S 03 12

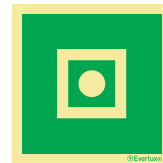

S 03 13



S 03 14



S 03 15



S 03 16



S 03 17

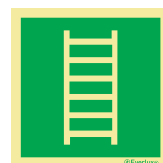

S 03 18



S 03 19

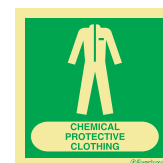

S 03 20



S 03 23

(mm)
300x100
400x150



S 03 31



S 03 32



S 03 33



S 03 34

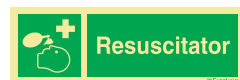

S 03 35



S 03 36



S 03 37



S 03 38



S 03 39



S 03 40



S 03 41



S 03 42



S 03 43



S 03 44



S 03 45



S 03 46



S 03 47



S 03 48



S 03 49



S 03 50



S 03 51



S 03 52



S 03 53



S 03 54









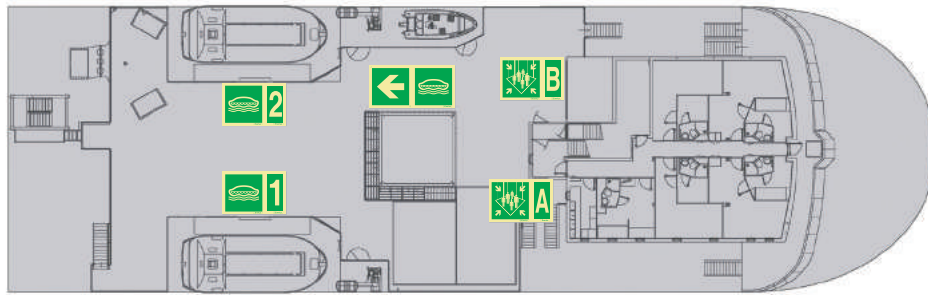

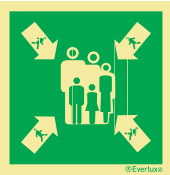
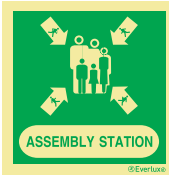

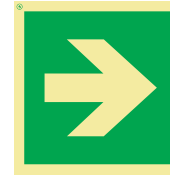
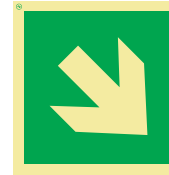
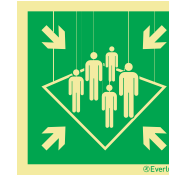











S 03 55

Muster Station and Embarkation Station signs











The objective of the escape route signing system is to ensure that a sign or a series of signs is provided and placed so that a person is directed along the escape route from any space within a ship or a marine installation towards an assembly station or embarkation station. The signing system should be designed based on the means of escape plan, assembly station plan, and lifesaving plan. It should provide simple information that will make it easy to identify the means of escape provisions, allow people to escape with minimum assistance and avoid possible points of confusion.



							(mm) 150x150 200x200 300x300 400x400
S 03 61	S 03 62	S 03 63	S 03 64	S 03 65	S 03 68		

				(mm) 300x100 400x120
	S 03 71	S 03 72		
				
S 03 73	S 03 74	S 03 75	S 03 76	
				
S 03 77	S 03 78	S 03 79	S 03 80	
				
S 03 81	S 03 82	S 03 83	S 03 84	
				
S 03 85	S 03 86	S 03 87	S 03 88	

As illustrated above, whenever the assembly stations are in a different location of the embarkation stations, the signing system should include egress route identification signs marking unambiguously the evacuation route from the assembly stations to the embarkation stations. This should be done with the adequate survival craft directional signs.

				(mm) 300x100 400x120
	S 03 89	S 03 90		
				
S 03 91	S 03 92	S 03 93	S 03 94	
				
S 03 95	S 03 96	S 03 97	S 03 98	

Escape route signs

Deck and Stair identification signs



(mm)
300x100
400x150
600x200



Number and letter supplementary signs for marking life-saving appliances and for other identification requirements

(mm)
75x150
100x200
150x300
200x400



...



...



Escape route signs according to ISO 24409 and EN ISO 7010

Escape route signs take priority over any other signs. These should be installed at consistent intervals of up to 15m in order to make it easier for evacuees to predict the location of the next evacuation sign.

Escape route signs should be installed at the center line over the doors at a height between 2.0m and 2.5m from the deck to the base of the sign in order to assure visibility from any foot traffic area. The escape route signs that are to be installed on bulkheads should be installed between 1.5m and 2.0m. As far as it is possible, installation heights should be kept throughout the escape route.

(mm)
300x150
400x200
600x300

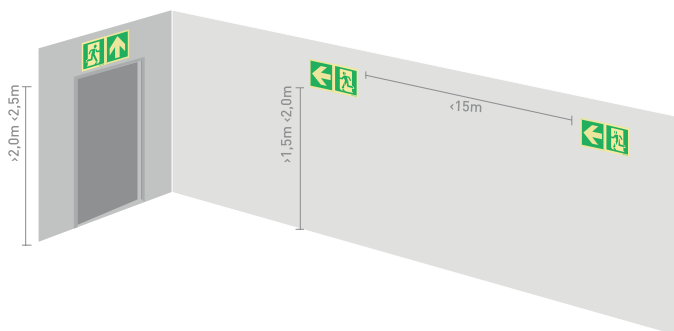

Escape route signs





Escape route signs according to ISO 24409 and EN ISO 7010













					(mm) 300x100 400x150 600x200
		S 04 35	S 04 36		
					
S 04 37	S 04 38	S 04 39	S 04 40		
					
S 04 41	S 04 42	S 04 43	S 04 44		
					
S 04 45	S 04 46	S 04 47	S 04 48		

							(mm) 300x150
S 04 51	S 04 52	S 04 53	S 04 54	S 04 55	S 04 56		

							(mm) [*]150x150 [*]200x200 300x300 400x400
		S 04 61	S 04 62	S 04 63	S 04 64		
							(*) Only available in this size
S 04 65	S 03 64	(*) S 04 67	S 03 65	S 03 66	S 03 67		

Escape route signs for people with reduced mobility

					(mm) 150x150 [*]150x200 200x200 [*]200x300 300x300
S 04 71	S 04 72	(*) S 04 75	(*) S 04 76		(*) Only available in this size

				(mm) [*]300x100 300x150 [*]400x150 400x200 [*]600x200 600x300
(*) S 04 91	(*) S 04 92	(*) S 04 93		
				
S 04 81	S 04 82	S 04 83	S 04 84	
				(*) Only available in this size
S 04 85	S 04 86	S 04 87	S 04 88	

Escape route signs

Escape door mechanism signs

(mm)
70x200
100x240(*)
100x300



S 05 01



S 05 02



(*) S 05 05



(*) S 05 06



(*) Only available
in this size

(mm)
300x150
400x200
600x300

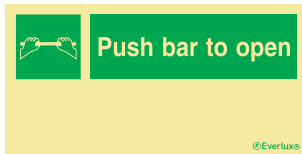

S 05 11

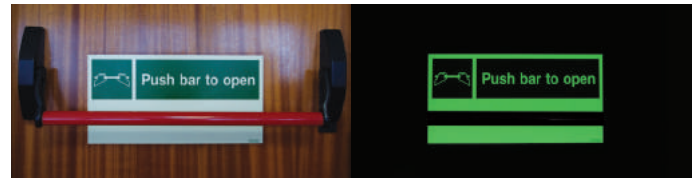

(mm)
200x70(*)
300x100
400x120
600x200(**)



(*) S 05 15

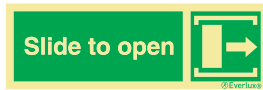

(*) S 05 16



(**) S 05 17



(*) S 05 18



(*) S 05 19

(*) (**)
Also available
in this size

(mm)
200x50
300x70
400x100



S 05 25

(mm)
100x100(*)
150x150
200x200
300x300
400x400(**)

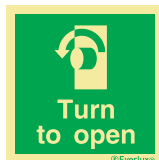

(*) S 05 31

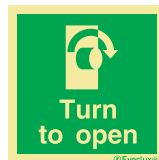

(*) S 05 32

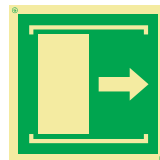

(**) S 05 33

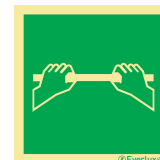

(**) S 05 34



(**) S 05 35

(*) (**)
Also available
in this size

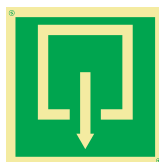

(**) S 05 36



(**) S 05 37



S 05 38



S 05 39

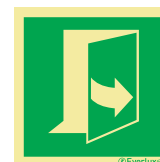

S 05 40

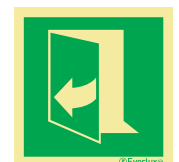

S 05 41

(mm)
200x70
300x100
400x120



S 05 51



S 05 52



S 05 53



S 05 54

(mm)
150x200
200x300
300x400



S 05 61



S 05 62



S 05 63



S 05 64

IMO fire control signs - according to IMO Resolution A.654 (16)



Safety and operating instructions for trained personnel (SIS) - As per ISO 24409, SIS signs are safety-related signs that replicate the symbols used in the Fire Control Plans and are used to provide safety and operational instructions for trained personnel that can be either crew members or external personnel that may need to come on-board.



(mm)
150x150
200x200



S 10 01
Fire control plan

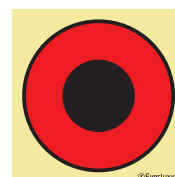

S 10 02
Push-button/switch for fire alarm

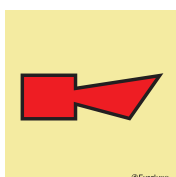

S 10 03
Horn fire alarm

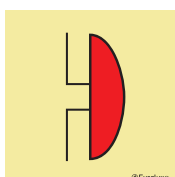

S 10 04
Bell fire alarm

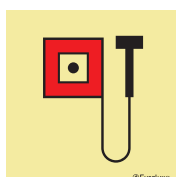

S 10 05
Manually operated call point



S 10 06
Space protected by automatic fire alarm

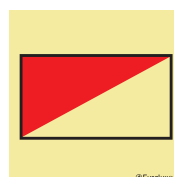

S 10 07
Fire alarm panel

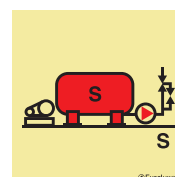

S 10 08
Sprinkler installation

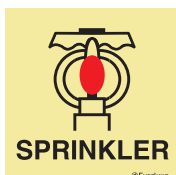

S 10 09
Space protected by sprinkler

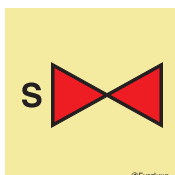

S 10 10
Sprinkler section valve

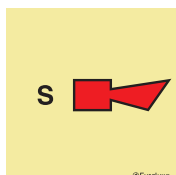

S 10 11
Sprinkler horn

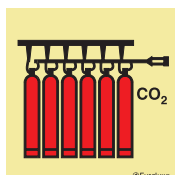

S 10 12
CO₂ battery

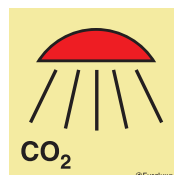

S 10 13
Space protected by CO₂

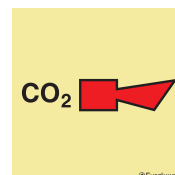

S 10 14
CO₂ horn

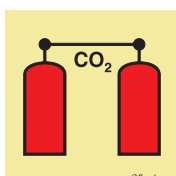

S 10 15
CO₂ release station



S 10 16
Halon 1301 battery



S 10 17
Space protected by halon 1301

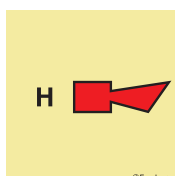

S 10 18
Halon horn

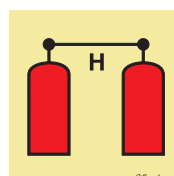

S 10 19
Halon release station

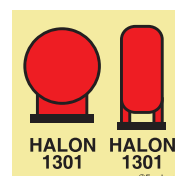

S 10 20
Halon 1301 bottles placed in protected area

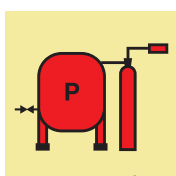

S 10 21
Powder installation



S 10 22
Powder monitor (gun)

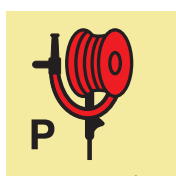

S 10 23
Powder hose and handgun

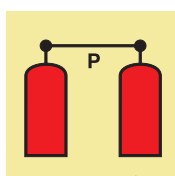

S 10 24
Powder release station

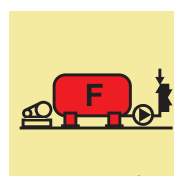

S 10 25
Foam installation



S 10 26
Foam monitor (gun)

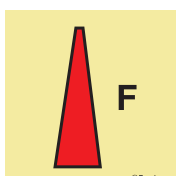

S 10 27
Foam nozzle

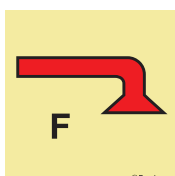

S 10 28
Space protected by foam

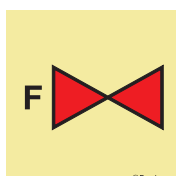

S 10 29
Foam valve

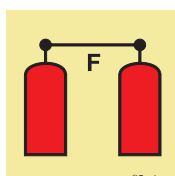

S 10 30
Foam release station



S 10 31
Hose box with spray/jet fire nozzle

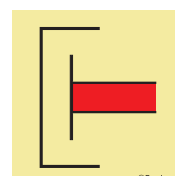

S 10 32
International shore connection

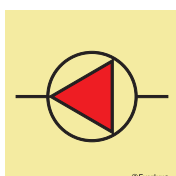

S 10 33
Fire pump

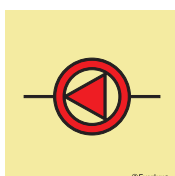

S 10 34
Emergency fire pump

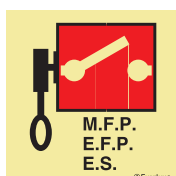

S 10 35
Remote control fire pumps or emergency switches

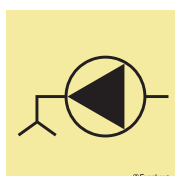

S 10 36
Bilge pump

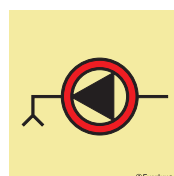

S 10 37
Emergency bilge pump



S 10 38
Water monitor (gun)

IMO fire control signs - according to IMO Resolution A.654 (16)

(mm)
150x150
200x200

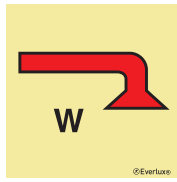

S 10 39
Water fog applicator

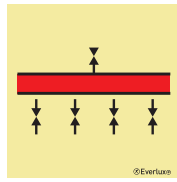

S 10 40
Drenching installation

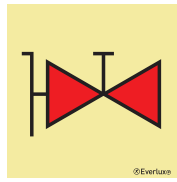

S 10 41
Fire mains
with fire valves

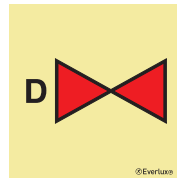

S 10 42
Section valves
drenching system

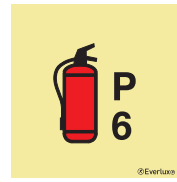

S 10 43
Powder portable fire
extinguisher - 6Kg

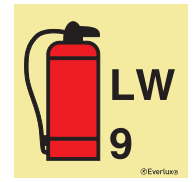

S 10 44
Foam portable fire
extinguisher - 9L



S 10 45
Halon 1211 portable fire
extinguisher - 4Kg

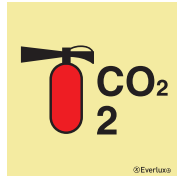

S 10 46
CO₂ portable fire
extinguisher - 2Kg

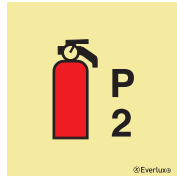

S 10 47
Powder fire
extinguisher - 2Kg

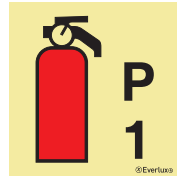

S 10 48
Powder fire
extinguisher - 1Kg

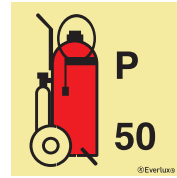

S 10 49
Powder wheeled fire
extinguisher - 50Kg

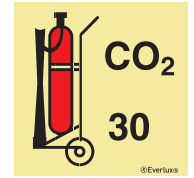

S 10 50
CO₂ wheeled fire
extinguisher - 30Kg

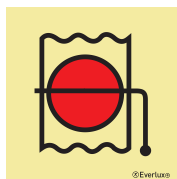

S 10 51
Fire damper in vent duct

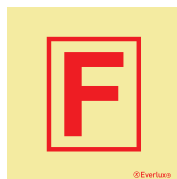

S 10 52
Fire station

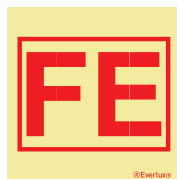

S 10 53
Locker with
fireman's outfit



S 10 54
Locker with additional
breathing apparatus

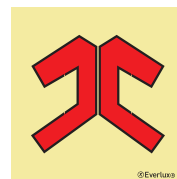

S 10 55
Locker for
protective clothing

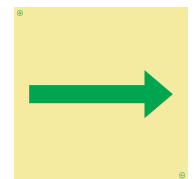

S 10 56
Primary means of
escape

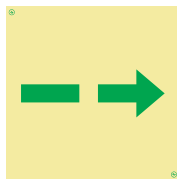

S 10 57
Secondary
means of escape

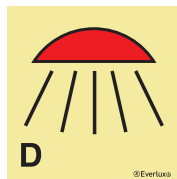

S 10 58
Space protected by
drenching system

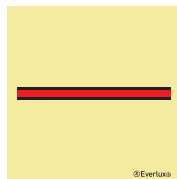

S 10 59
A class division

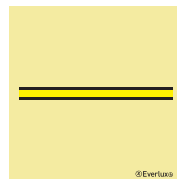

S 10 60
B class division

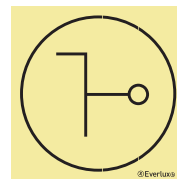

S 10 61
Remote controlled
skylights

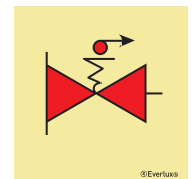

S 10 62
Remote controlled fuel/
lubricating oil valves

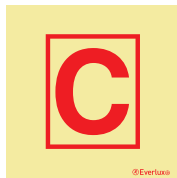

S 10 63
Control station

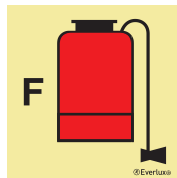

S 10 64
Portable foam applicator



S 10 65
Inert gas installation

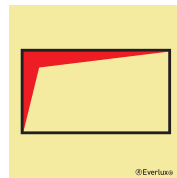

S 10 66
High expansion
foam supply trunk

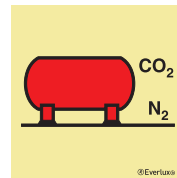

S 10 67
CO₂ / nitrogen bulk
installation

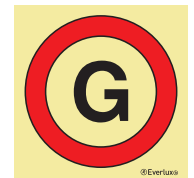

S 10 68
Emergency generator

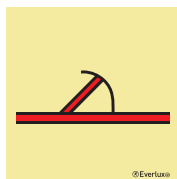

S 10 69
A class fire door

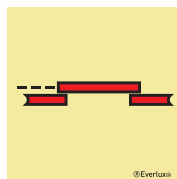

S 10 70
A class sliding fire door

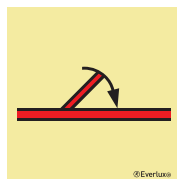

S 10 71
A class fire door
self-closing

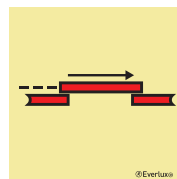

S 10 72
A class sliding
door self-closing

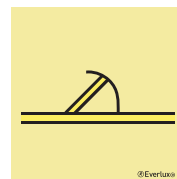

S 10 73
B class fire door

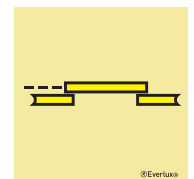

S 10 74
B class sliding fire door

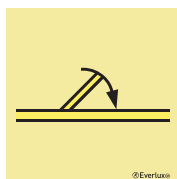

S 10 75
B class fire door
self-closing

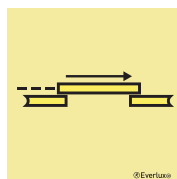

S 10 76
B class sliding fire door
self-closing

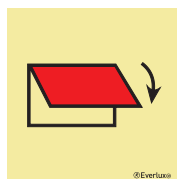

S 10 77
Closing appliance for
exterior ventilation
inlet or outlet

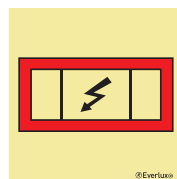

S 10 78
Emergency switchboard

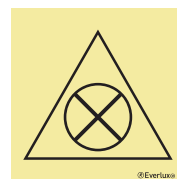

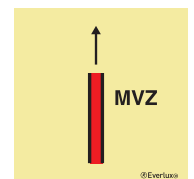

S 10 79
Remote ventila-
tion shut off





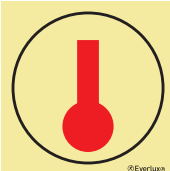
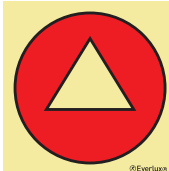
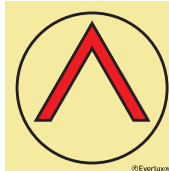
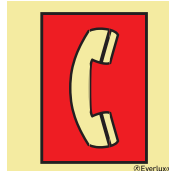
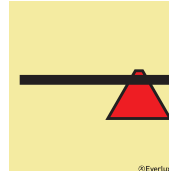

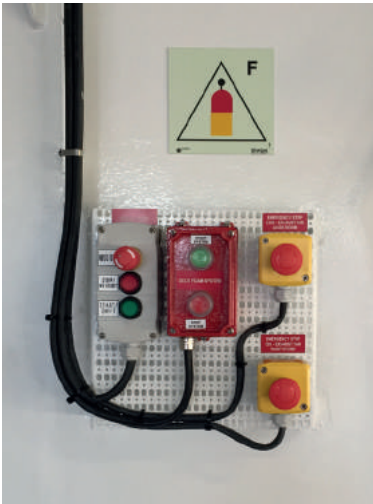
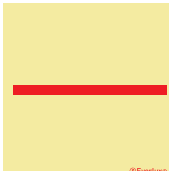
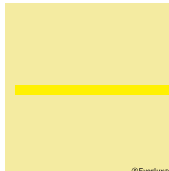
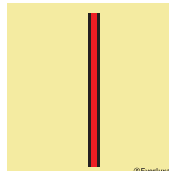
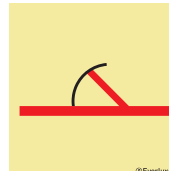

S 10 80
Main vertical zone

IMO fire control signs - according to IMO Resolution A.654 (16)

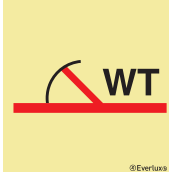
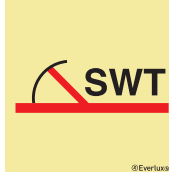
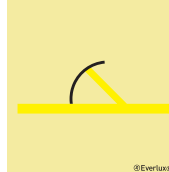
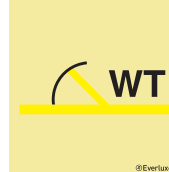
							(mm) 150x150 200x200
S 10 81 Smoke detector	S 10 82 Heat detector	S 10 83 Gas detector	S 10 84 Flame detector	S 10 85 Emergency telephone station	S 10 86 Fire axe		

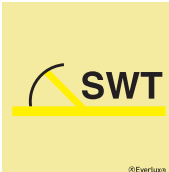
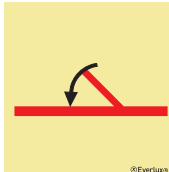
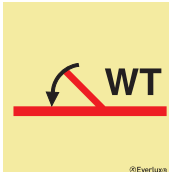
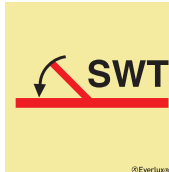
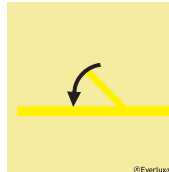
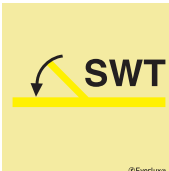
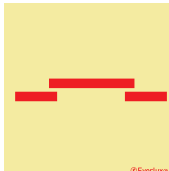
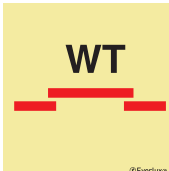
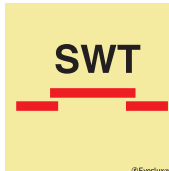
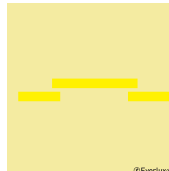
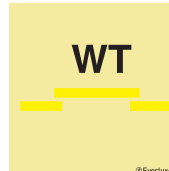
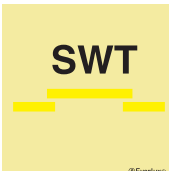
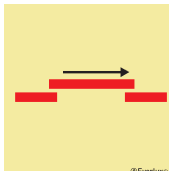
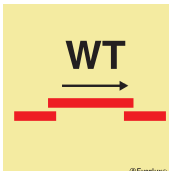
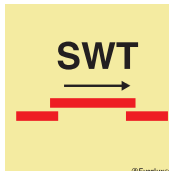
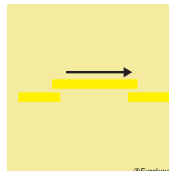
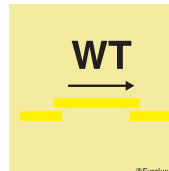
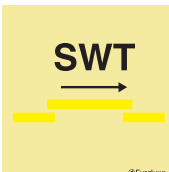
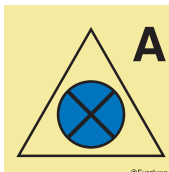
IMO fire control signs - according to IMO Resolution A.952 (23), ISO 17631 and ISO 24409

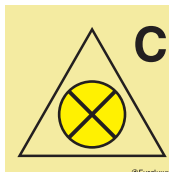
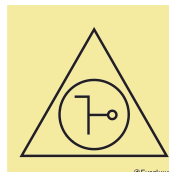
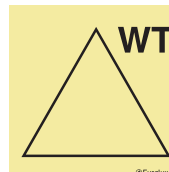
						(mm) 150x150 200x200
	S 12 01 A-class division	S 12 02 B-class division	S 12 03 Main vertical zone	S 12 04 A-class hinged fire door		
						
	S 12 05 A-class watertight fire door	S 12 06 A-class semi-watertight fire door	S 12 07 B-class hinged fire door	S 12 08 B-class watertight fire door		
						
S 12 09 B-class semi-watertight fire door	S 12 10 A-class hinged self-closing fire door	S 12 11 A-class watertight self-closing fire door	S 12 12 A-class semi-watertight self-closing fire door	S 12 13 B-class hinged self-closing fire door	S 12 14 B-class watertight self-closing fire door	
						
S 12 15 B-class semi-watertight self-closing fire door	S 12 16 A-class sliding fire door	S 12 17 A-class watertight sliding fire door	S 12 18 A-class semi-watertight sliding fire door	S 12 19 B-class sliding fire door	S 12 20 B-class watertight sliding fire door	
						
S 12 21 B-class semi-watertight sliding fire door	S 12 22 A-class self-closing sliding fire door	S 12 23 A-class self-closing watertight sliding fire door	S 12 24 A-class self-closing semi-watertight sliding fire door	S 12 25 B-class self-closing sliding fire door	S 12 26 B-class self-closing watertight sliding fire door	
						
S 12 27 B-class self-closing semi-watertight sliding fire door	S 12 28 Ventilation remote control shut-off for accommodation and service spaces	S 12 29 Ventilation remote control shut-off for machinery spaces	S 12 30 Ventilation remote control shut-off for cargo spaces	S 12 31 Remote control for skylight	S 12 32 Remote control for watertight doors	

IMO fire control signs - according to IMO Resolution A.952 (23), ISO 17631 and ISO 24409

(mm)
150x150
200x200

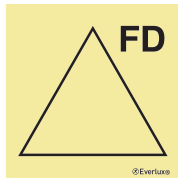

S 12 33
Remote control for fire doors

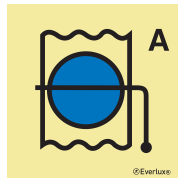

S 12 34
Fire damper for accommodation and service spaces

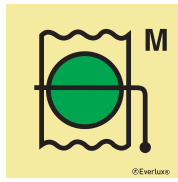

S 12 35
Fire damper for machinery spaces

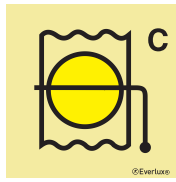

S 12 36
Fire damper for cargo spaces

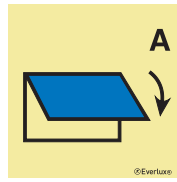

S 12 37
Closing device for ventilation inlet or outlet for accommodation and service spaces

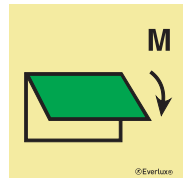

S 12 38
Closing device for ventilation inlet or outlet for machinery spaces

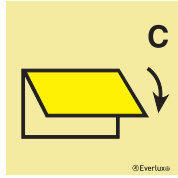

S 12 40
Closing device for ventilation inlet or outlet for cargo spaces

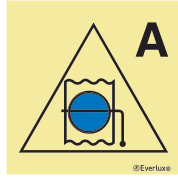

S 12 40
Remote control for fire damper(s) for accommodation and service spaces

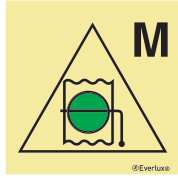

S 12 41
Remote control for fire damper(s) for machinery spaces

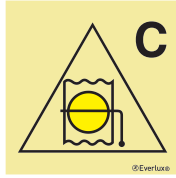

S 12 42
Remote control for fire damper(s) for cargo spaces

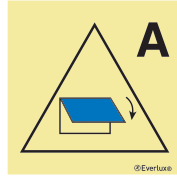

S 12 43
Remote control for closing device(s) for ventilation inlet and outlet for accommodation and service spaces

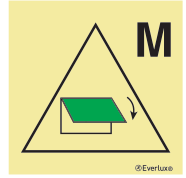

S 12 44
Remote control for closing device(s) for ventilation inlet and outlet for machinery spaces

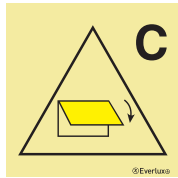

S 12 45
Remote control for closing device(s) for ventilation inlet and outlet for cargo spaces



S 12 46
Fire protection appliances or structural fire protection plan

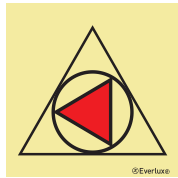

S 12 47
Remote control for fire pump(s)

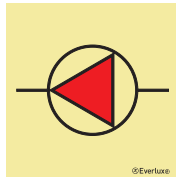

S 10 33
Fire pump(s)

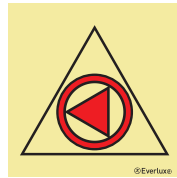

S 12 49
Remote control for emergency fire pump or fire pump supplied by the emergency source of power

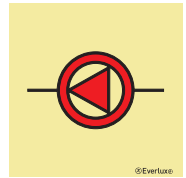

S 10 34
Emergency fire pump

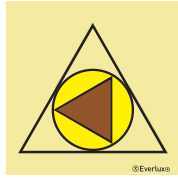

S 12 51
Fuel pump(s) remote shut-off

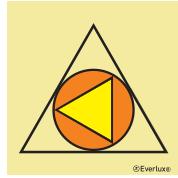

S 12 52
Lube oil pump(s) remote shut-off

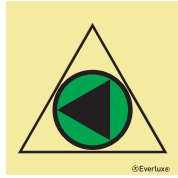

S 12 53
Remote control for bilge pump(s)

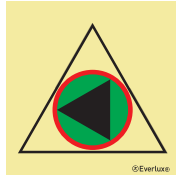

S 12 54
Remote control for emergency bilge pump

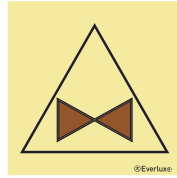

S 12 55
Remote control for fuel oil valves

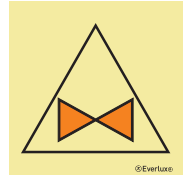

S 12 56
Remote control for lube oil valves

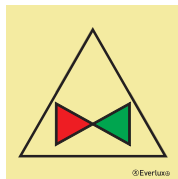

S 12 57
Remote control for fire pump valve(s)

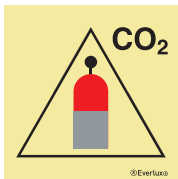

S 12 58
CO₂ remote release station

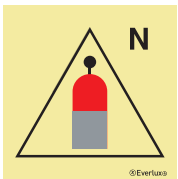

S 12 59
Nitrogen remote release station

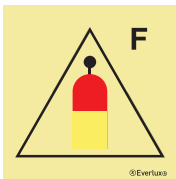

S 12 60
Foam remote release station

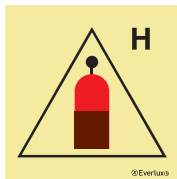

S 12 61
Gas remote release station

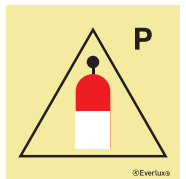

S 12 62
Powder remote release station

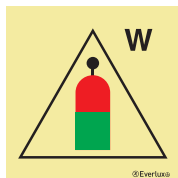

S 12 63
Water remote release station

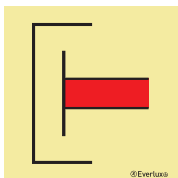

S 10 32
International shore connection

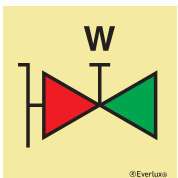

S 12 65
Fire hydrant

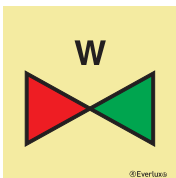

S 12 66
Fire main section valve

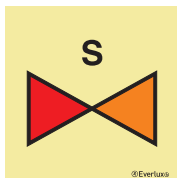

S 12 67
Sprinkler-section valve

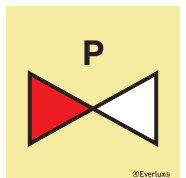

S 12 68
Powder-section valve

IMO fire control signs - according to IMO Resolution A.952 (23), ISO 17631 and ISO 24409

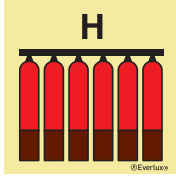
						     	(mm) 150x150 200x200
							
S 12 69 Foam-section valve	S 12 70 CO ₂ fixed fire-extinguishing installation	S 12 71 Nitrogen fixed fire-extinguishing installation	S 12 72 Foam fixed fire-extinguishing installation	S 12 73 Gas fixed fire-extinguishing installation	S 12 74 Powder fixed fire-extinguishing installation		
							
S 12 75 Water fixed fire-extinguishing installation	S 12 76 CO ₂ fixed fire-extinguishing battery	S 12 77 Nitrogen fixed fire-extinguishing battery	S 12 78 Foam fixed fire-extinguishing battery	S 12 79 Gas fixed fire-extinguishing battery	S 12 80 Powder fixed fire-extinguishing battery		
							
S 12 81 Water fixed fire-extinguishing battery	S 12 82 CO ₂ fixed fire-extinguishing bottle, placed in protected area	S 12 83 Nitrogen fixed fire-extinguishing bottle, placed in protected area	S 12 84 Foam fixed fire-extinguishing bottle, placed in protected area	S 12 85 Gas fixed fire-extinguishing bottle, placed in protected area	S 12 86 Powder fixed fire-extinguishing bottle, placed in protected area		
							
S 12 87 Water fixed fire-extinguishing bottle, placed in protected area	S 12 88 High-expansion-foam supply trunk (outlet)	S 10 40 Water-spray-system valves	S 10 65 Inert gas installation	S 12 91 Foam monitor	S 12 92 Powder monitor		
							
S 12 93 Water monitor	S 12 94 Foam fire hose and nozzle	S 12 95 Powder fire hose and nozzle	S 12 96 Water fire hose and nozzle	S 12 97 Portable foam applicator unit or relevant spare tank(s)	S 12 98 Fire locker		
							
S 12 99 Spaces or group of spaces protected by CO ₂ fire-extinguishing system	S 13 00 Spaces or group of spaces protected by foam fire-extinguishing system	S 13 01 Spaces or group of spaces protected by gas fire-extinguishing system	S 13 02 Spaces or group of spaces protected by powder fire-extinguishing system	S 13 03 Spaces or group of spaces protected by water fire-extinguishing system	S 13 04 Spaces or group of spaces protected by sprinkler or high pressure fire-extinguishing system		
							
S 13 05 Water fog applicator	S 13 68 Emergency source of electrical power (generator)	S 13 07 Emergency source of electrical power (battery)	S 10 78 Emergency switchboard	S 13 09 Air compressor for breathing devices	S 13 10 Control panel for fire detection and alarm system		

IMO fire control signs - according to IMO Resolution A.952 (23), ISO 17631 and ISO 24409

(mm)
150x150
200x200

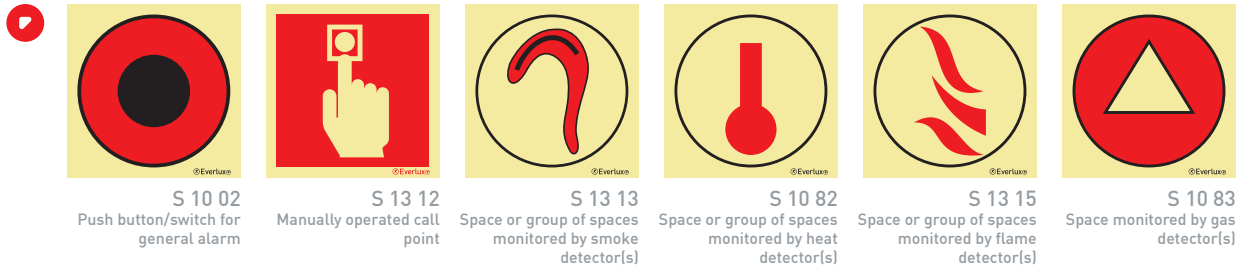

IMO fire control signs - fire extinguisher according to IMO Resolution A.952 (23) and ISO 17631

(mm)
150x150
200x200

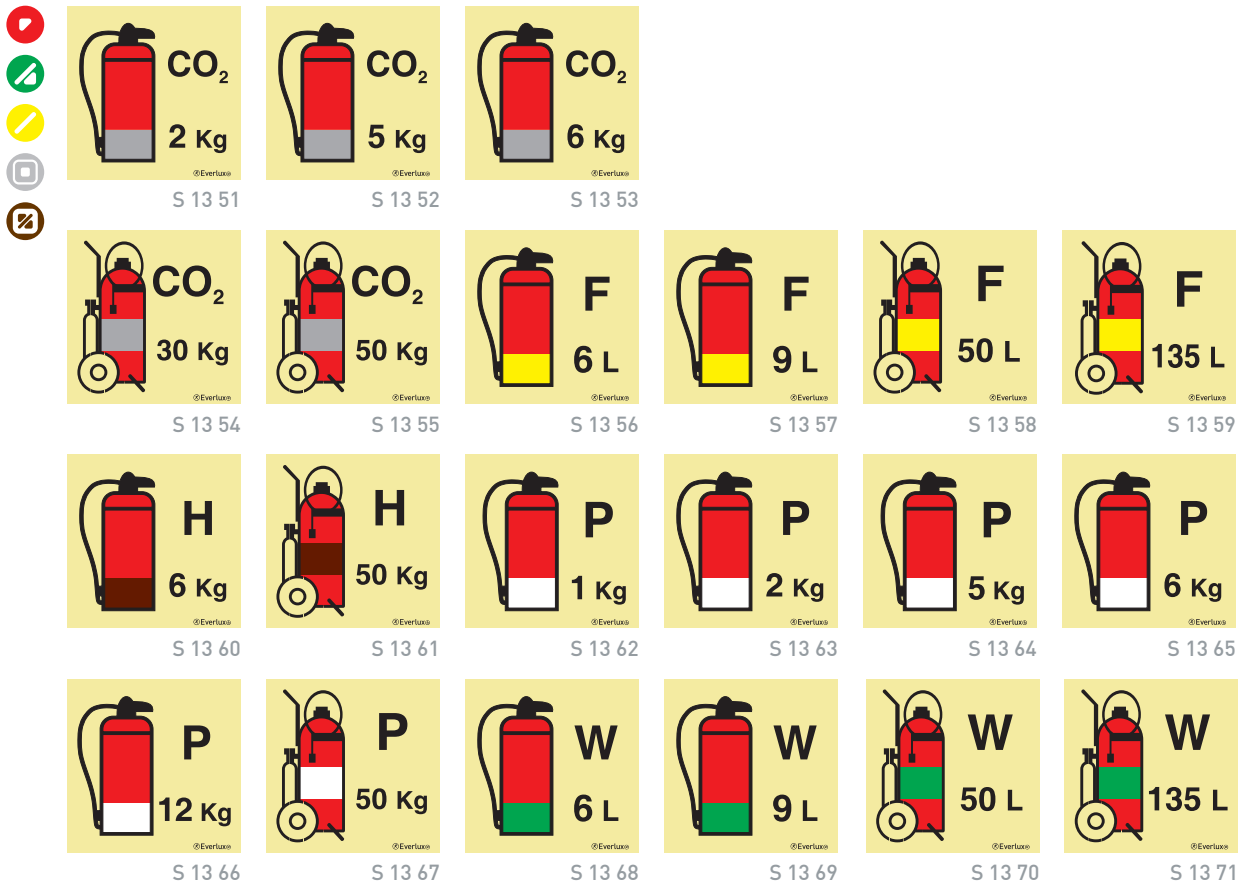

(mm)
150x150
200x200

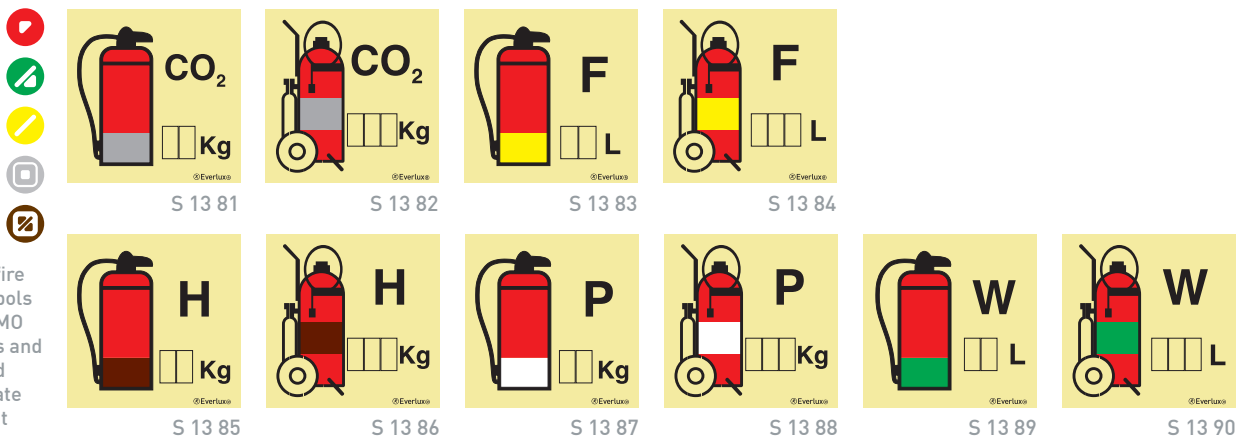

These signs with fire extinguisher symbols are according to IMO and ISO Standards and can be customized with the appropriate extinguisher agent capacity

IMO fire control signs - fire extinguisher according to IMO Resolution A.952 (23) and ISO 17631

These sheets are available in two different formats: one format contains the same digit and the other contains multiple digits. The sheets in single digit format are available with numbers 1 to 0. There are 90 numbers supplied on each sheet. The multiple digit sheet contains the most commonly used numbers in greater quantities and should allow the identification of up to 24 fire extinguishers.

(mm)
15x28
A4 page

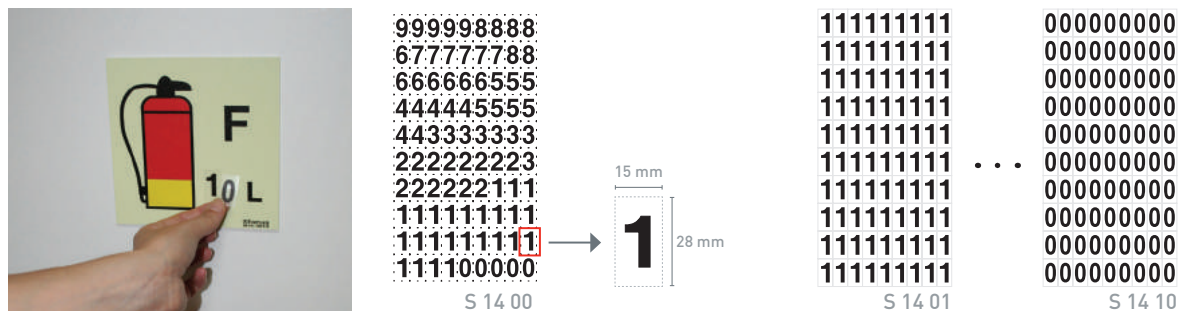

Non-standard Fire Control IMO signs



Fire-fighting equipment signs in compliance with ISO 24409 and EN ISO 7010



(mm)
150x150
200x200
300x300



S 16 01



S 16 02

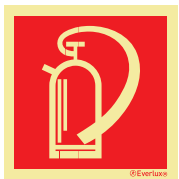

S 16 03

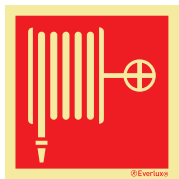

S 16 05



S 16 06



S 16 07



S 16 08

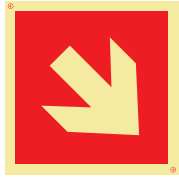

S 16 09

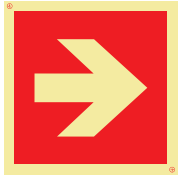

S 16 10



S 16 91



S 16 92



S 16 93



S 16 94



S 16 95



S 16 96



S 16 97



S 16 98



S 16 99

(mm)
100x200
150x300
200x400



S 16 51



S 16 52



S 16 53



S 16 54



S 16 55

Fire fighting equipment signs

(mm)
100x300



S 16 85

To indicate when an extinguisher is missing a sign can be placed on the wall behind the extinguisher that displays the telephone number of the service agent or supplier

Supplementary Signs, Combination Signs and Multiple Signs



Supplementary signs provide complementary information and will extend the safety message communicated by the referent of a given safety sign. There are supplementary explanatory signs, supplementary directional arrow signs and supplementary identification signs. When a safety sign is used in conjunction with a supplementary sign, that conjunction becomes a combination sign. The example on the left hand side uses a fire extinguisher sign together with several supplementary signs.

When a text supplementary sign is used then it should use the languages that are appropriate to the service of the ship and the working language on-board the vessel as illustrated in this example using a fire extinguisher identification supplementary sign with English and Russian text.

Fire fighting equipment signs with supplementary text



Fire Extinguisher Signs with Integrated Supplementary Extinguishing Agent ID Sign

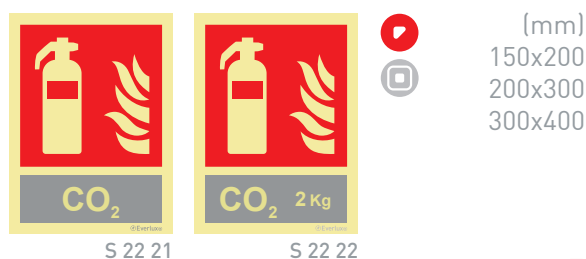

Fire Extinguisher Signs with Integrated Supplementary Extinguishing Agent ID Sign

(mm)
150x200
200x300
300x400



(mm)
200x150
300x200
400x300

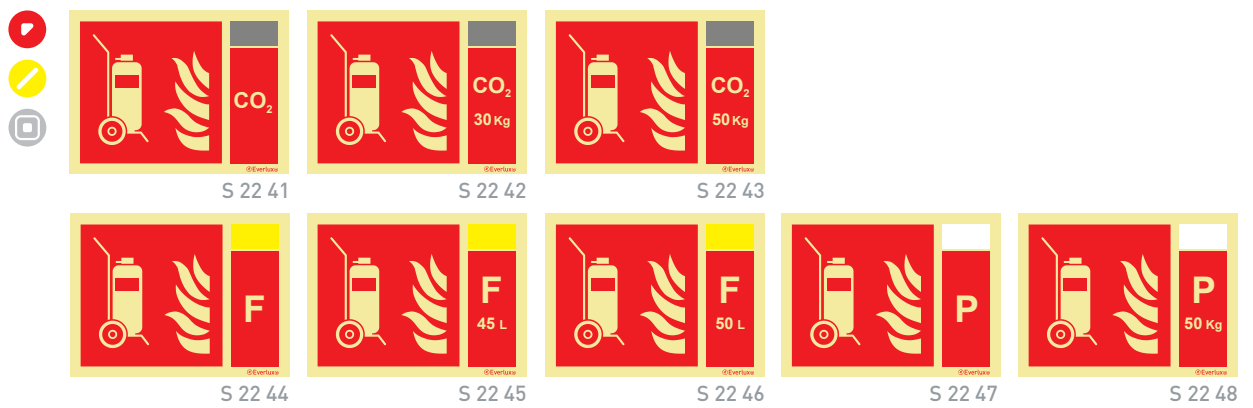

(mm)
150x200
200x300
300x400



Fire Hose Reel Signs with Integrated Supplementary Extinguishing Agent ID Sign

(mm)
200x150
300x200
400x300



Fire Hose Reel Signs with Integrated Supplementary Extinguishing Agent ID Sign



Portable Foam Applicator Signs with Integrated Supplementary Extinguishing Agent ID Sign

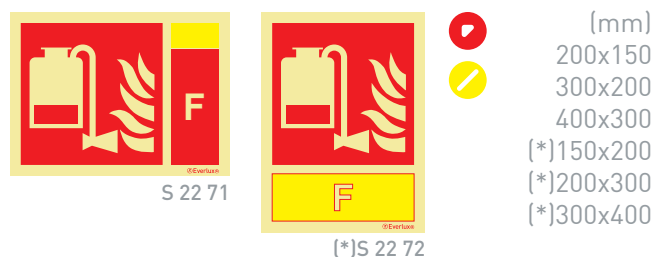

Fog Applicator Signs with Integrated Supplementary Extinguishing Agent ID Sign



Fixed Fire-extinguishing Battery Signs with Integrated Supplementary Extinguishing Agent ID Sign



Fixed Fire-extinguishing Bottle Signs with Integrated Supplementary Extinguishing Agent ID Sign

(mm)
200x150
300x200
400x300



(mm)
150x200
200x300
300x400



Fixed Fire-extinguishing Installation Signs with Integrated Supplementary Extinguishing Agent ID Sign

(mm)
200x150
300x200
400x300



(mm)
150x200
200x300
300x400

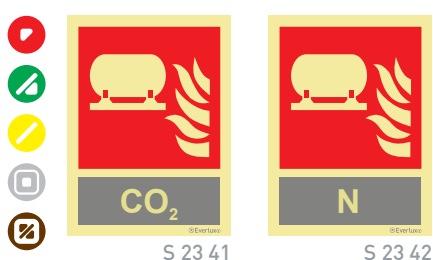

Fixed Fire-extinguishing Installation Signs with Integrated Supplementary Extinguishing Agent ID Sign

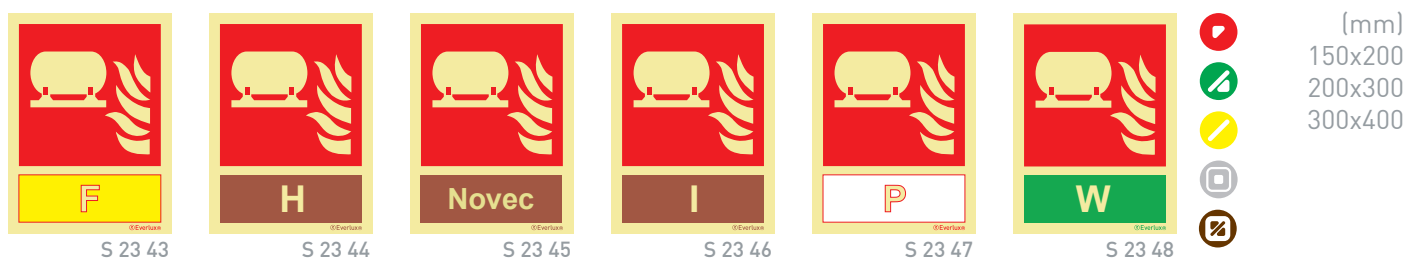

Remote Release Station Signs with Integrated Supplementary Extinguishing Agent ID Sign



Fire Monitor Signs with Integrated Supplementary Extinguishing Agent ID Sign



Fire

Numbers and other supplementary signs for marking fire fighting equipment and other identification requirements

(mm)
75x150
100x200
150x300

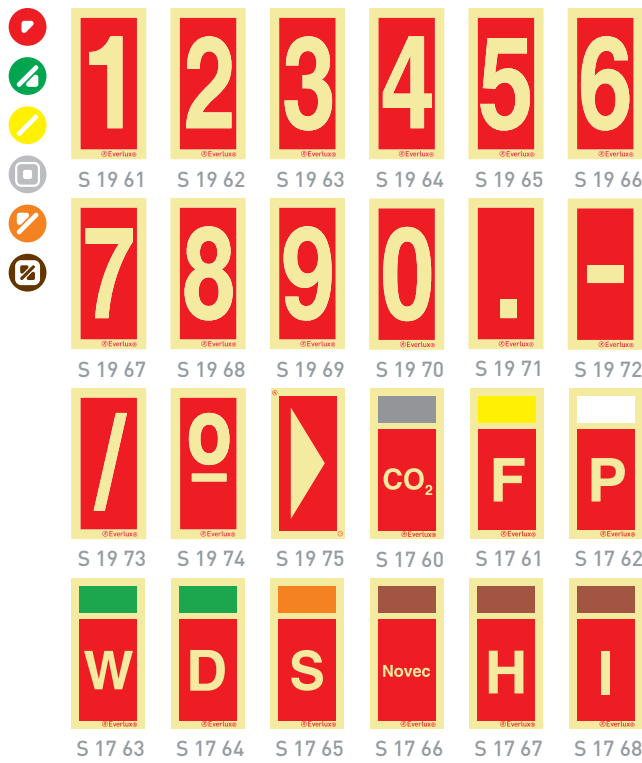

Fire extinguisher identification signs

(mm)
75x200

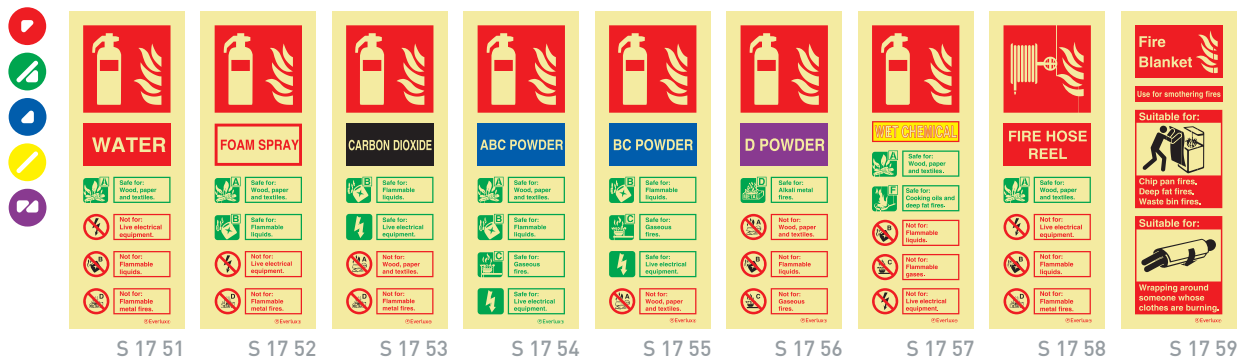





(mm)
150x100
200x150

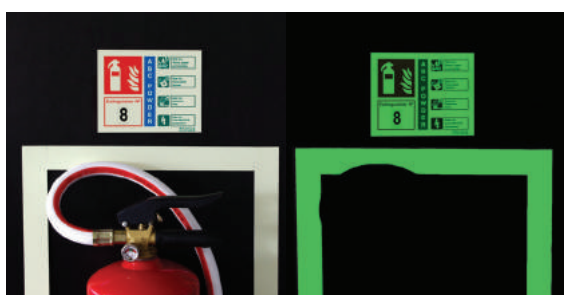

Numbered fire extinguisher identification signs



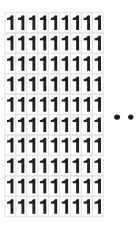





				(mm) 150x120
S 17 91	S 17 92	S 17 93		
				
S 17 94	S 17 95	S 17 96	S 17 97	

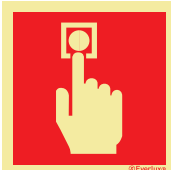

			(mm) 15x28 A4 page
S 14 00	S 14 01	S 14 10	

Fire alarm signs

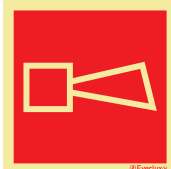

			(mm) 150x150 200x200 300x300
S 18 02	S 18 02		
			
S 18 03	S 18 04	S 18 05	
			
S 18 06	S 18 07	S 18 08	

				(mm) 150x200 200x300 300x400
S 18 21	S 18 22	S 18 23		

Signs for lifts

(mm)
150x200
200x300



S 18 41



S 18 42



S 18 43



S 18 44



S 18 45



S 18 46



S 18 47



S 18 48



S 18 49



S 18 50

Signs with supplementary text

(mm)
200x70(*)
300x100
400x120



S 19 01



S 19 02



S 19 03



S 19 04



S 19 05



S 19 06



S 19 07



S 19 08



S 19 09



S 19 10



(*) S 19 11



(*) S 19 12



S 19 13



S 19 14



S 19 15

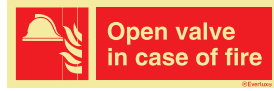

S 19 16



(*) S 19 17

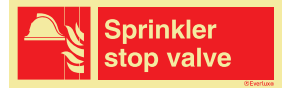

(*) S 19 18



S 19 19



S 19 20



S 19 21



S 19 22



S 19 23

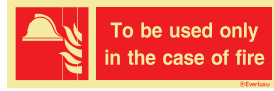

S 19 24



S 19 25



S 19 26



S 19 27



S 19 28



(*) S 19 29



S 19 30



S 19 31



S 19 32

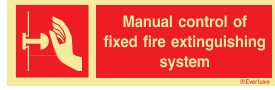

S 19 33



S 19 34

Low Location Lighting system

The spreading of smoke is one of the most dangerous consequences of a fire rendering evacuation difficult and in some cases impossible. Under these conditions, visibility is reduced causing panic and increasing the evacuation time which is a critical factor in avoiding intoxication which can lead to death.

The  Everlux® Low Location Lighting (LLL) system is a unique system that allows all evacuation routes to stay illuminated, thereby communicating a clear, continuous and unambiguous “means of escape” message which leads to a safe place. The locations of fire fighting equipment are also clearly marked as part of the system along the escape routes.

This LLL system is unique in providing consistent and regular information throughout the complete escape route. This reduces possible confusion and panic, factors that hamper the safe egress from occupied areas.

According to IMO Resolution A. 752 (18) all means of egress must be marked with Low Location Lighting system at all points of the evacuation route. The LLL system is also recommended by ISO Standards, namely ISO 15370.

The

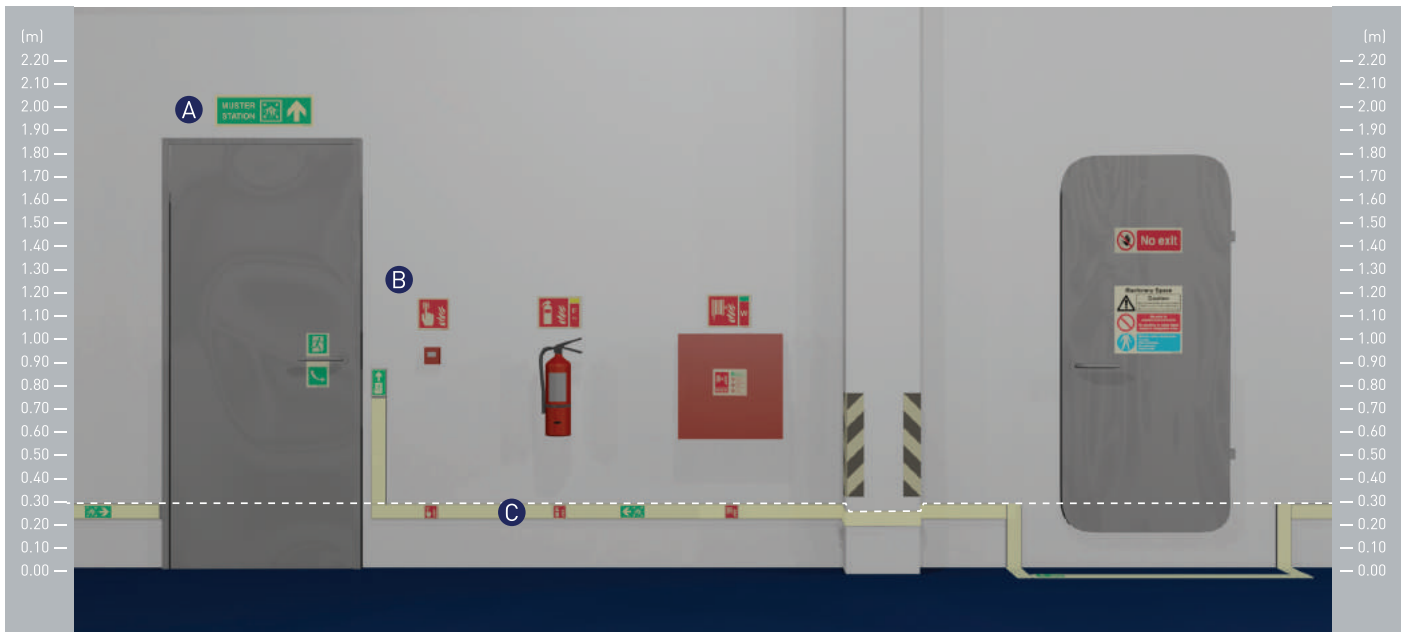

illustration below depicts a complete safety signage system installed on board:

A - Photoluminescent signs installed at a high location level (above 2m) are to be visible and identified from further distances.

B - Photoluminescent signs installed at an intermediate location level. Per ISO 24409 fire-fighting equipment signs shall be installed either directly on the fire-fighting equipment or as close as practicable.

Recommended range for signs with text providing information and/or instructions to the user.

C - Photoluminescent signs at a low location level (within 30cm from deck according to SOLAS 2004 Chapter II Regulation 13.3.3.5 and ISO 15370): a sign system that illuminates the entire escape route and identifies the location of fire fighting equipment at floor level.

The components of the  Everlux® Low Location Lighting system are:

- Photoluminescent rigid plastic strips and signs to be applied on walls.

- Floor marking strips: 0.3mm thick non-slip photoluminescent self-adhesive marking strips and signs to be applied directly to the floor.

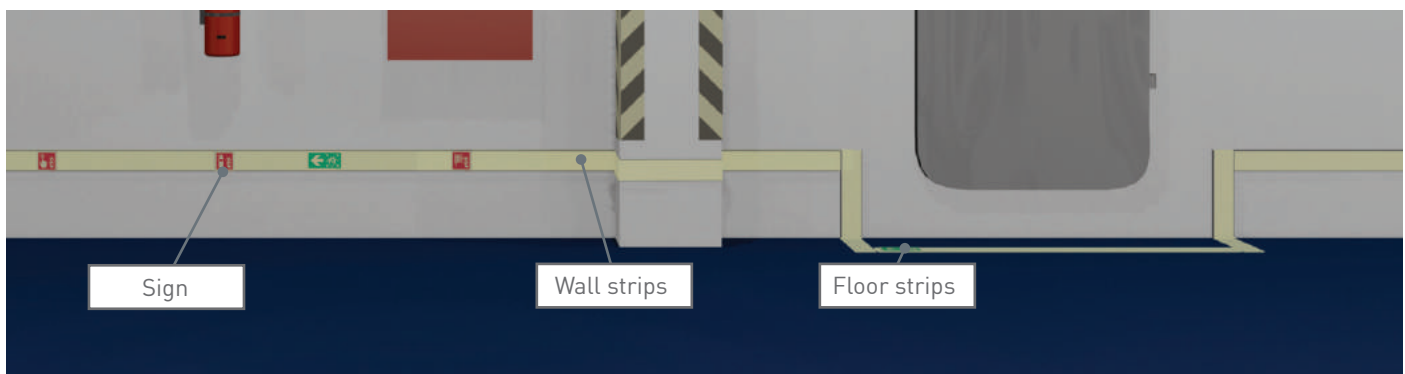



Low Location Lighting

Example

Escape doors must be signed as illustrated.



Stairs and corridors which are 2m wide or more should be fitted with LLL photoluminescent strips on both sides.



Photoluminescent directional signs must be placed at each change of level.

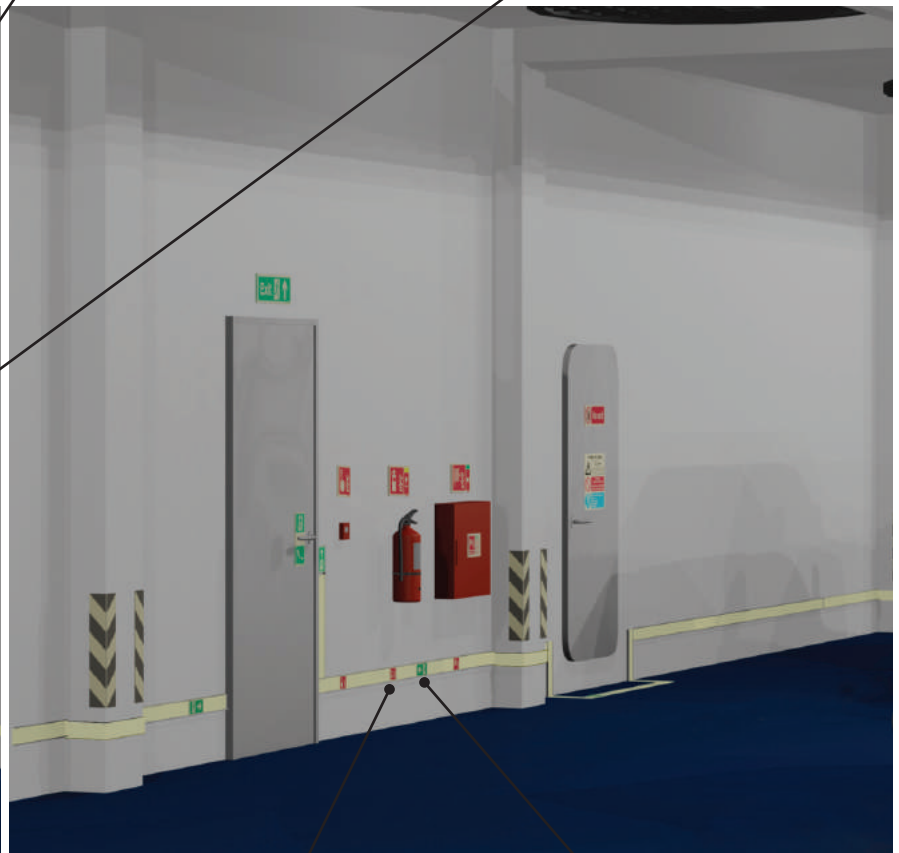
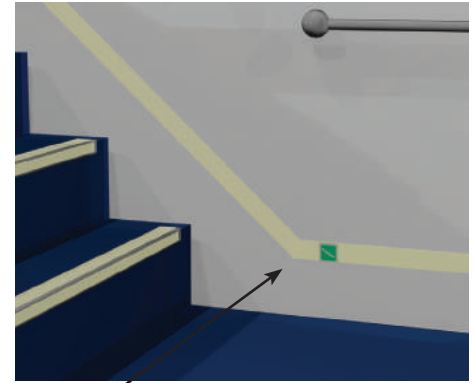

Non-escape doors must be signed as illustrated.

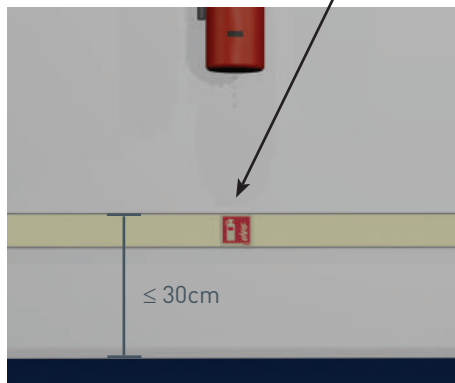

According to Solas 2004 Chapter II Regulation 13.3.3.5 and IMO Resolution A.752 (18) photoluminescent marking strips must be placed not more than 30cm above the deck at all points of the escape route.

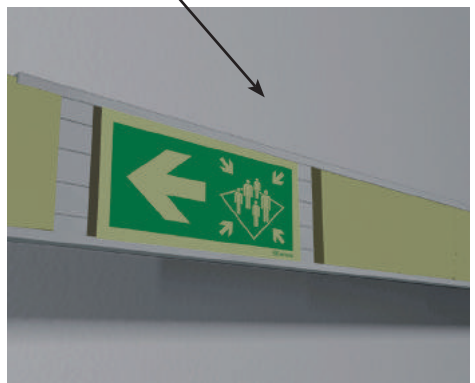

Directional escape route signs complement the continuous photoluminescent strip installed in aluminium rail.

Normative and legal framework, technical performances and properties

Guidance systems at floor level (Low Location Lighting) began with legislation covering the areas of greatest risk. Firstly in aviation with FAA in 1984 and then in the maritime industry with IMO Regulations in 1989.

Since 1999, following the development of new photoluminescent technologies, other authorities have begun the process of standardising these systems.

Important Standards	IMO Resolution A.752 (18)	Guidelines for the evaluation, testing and application of low-location lighting on passenger ships
	SOLAS Convention 2004	Means of escape - Marking of escape routes
	European Directive 2002/25/EC	Safety rules and standards for passenger ships
	ISO 15370	Low Location Lighting (LLL) on passenger ships
	ISO 16069	SWGS - Safety Way Guidance Systems
	ISO 3864	Graphical symbols - safety colours and safety signs

Ⓢ Everlux® Low Location Lighting Strip and Sign System:

The strip and sign system can be mounted directly to walls using the Ⓢ Everlux® adhesive or with the aluminium frames.

According to IMO A.752 (18) his system shall be positioned in the following way, throughout the escape routes:

- Where a corridor has a width of 2m or more the guidance line shall be applied continuously on both sides of the corridor.
- Where the width is less than 2m, one guidance line may be sufficient and should be as continuous as possible on the side where the fire fighting equipment is located. If there is no fire fighting equipment the strips should be applied continuously on the side that leads to the door handle.
- The strips should not be installed more than 30cm above deck.

Ⓢ Everlux®-LLL Strip and Sign System for Floors and Stairs:

The strip and sign system can be placed directly onto floors and stairs using the integral high adherence adhesive. Simply remove the backing material and position accurately.

Luminance Properties			
Applicable Resolutions and Standards/ Product	Luminance Intensity (mcd/m ²) (After removing the exciting light)		Period of Light Decay Luminance Intensity greater than a 0.3 mcd/ m ²
	10 minutes	60 minutes	
IMO Resolution A.752(18) a)	15 mcd/m ²	2.0 mcd/m ²	...
ISO 15370 a)	15 mcd/m ²	2.0 mcd/m ²	...
Ⓢ Everlux® a)	40 mcd/m ²	8 mcd/m ²	1800 minutes
Ⓢ Everlux®-LLL b)	80 mcd/m ²	10 mcd/m ²	1000 minutes

a) Values obtained with a stimulation of only 25 lux, during 24 hours with a fluorescent lamp with colour temperature of 4000K, according to ISO 15370 measurement protocol.

b) Values obtained with a stimulation of only 25 lux, during 15 minutes with a fluorescent lamp with colour temperature of 6500K, according to ISO 16069 measurement protocol.

All signs have a high photoluminescent intensity which is achieved with as little as a 25 lux charge from an ambient light source

Base Materials:

Signs and strips for wall mounting: Photoluminescent rigid plastic 1.2mm thick; photoluminescent self-adhesive vinyl;

Signs and strips for floors and stairs: Photoluminescent non-slip self-adhesive polycarbonate 0.3mm thick;

Transparent vinyl signs are also available to complement the Ⓢ Everlux® Low Location Lighting system.

Printing: Serigraphy, high gloss paint with a high UV resistance.

Chemical Characteristics: Non-phosphorous, non-radioactive, lead-free and non-poisonous.



Low Location Lighting

Turnkey safety signage projects



Ⓢ Everlux® adopts an integrative approach to every safety signage project the company is involved with from project development through to installation and project delivery. When hiring Ⓢ Everlux® for a turnkey safety signage project, customers benefit from a high quality on time service which includes on-board and remote surveys, life-safety and fire control plan and Low Location Lighting project development using the Ⓢ Everlux® Project maritime tool, supply, installation, on-board luminance measurements, project management, documentation and delivery.

The Ⓢ Everlux® turnkey safety signage project service is the ideal solution for owners, shipyards or marine outfitters who are involved with new-build or major refurbishment on vessels or oil rigs.



Photoluminescent low location lighting system inspections and measurement service

Ⓢ Everlux® has the Approval as Service Supplier by DNV for photoluminescent Low Location Lighting measurements. Our technicians are available worldwide to help you meet the classification bodies' requirements in a fast and cost-effective way.

The inspection and measurement reports on photoluminescent LLL systems are mandatory according to IMO Resolution A.752 (18), adopted on 4 November 1993. These guidelines cover the approval, installation and maintenance of low location lighting (LLL) required by regulations II-2/28, paragraph 1.10 and II-2/41-2, paragraph 4.7 of the 1974 SOLAS Convention, as amended, on all passenger ships carrying more than 36 passengers, to readily identify the passengers' route of escape when the normal emergency lighting is less effective due to smoke.

According to IMO Resolution A.752 (18), chapter 9, a maintenance of LLL systems should be visually examined and checked once a week and a record kept. All missing, damaged or inoperable LLL components should be replaced.

All LLL systems should have their luminance tested at least once every five years.

Readings should be taken on site. If the luminance for a particular reading does not meet the requirement of these guidelines, readings should be taken in at least ten locations equally spaced apart in the space. If more than 30% of the readings do not meet the requirements of these guidelines, the entire LLL system should be replaced.

If between 20% and 30% of the readings do not meet the requirements of these guidelines, the LLL system should be checked again in one year or may be replaced.

For detailed information on the Ⓢ Everlux® turnkey safety signage project service or on the mandatory requirements, inspection and measurement reports of photoluminescent LLL systems, please contact us at commercial@everluxmaritime.com.



Ⓢ Everlux® project maritime

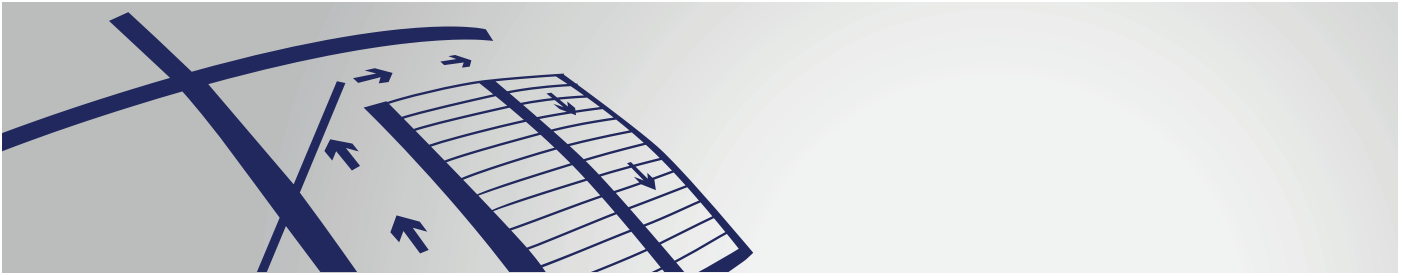

Ⓢ Everlux® project maritime is a software support tool for the development of safety signage and Low Location Lighting (LLL) projects and respective bill of quantities. This tool facilitates the most adequate selection of safety signs and provides installation companies with the right technical documentation to assure that the safety signs that are projected will be installed onboard simultaneously reducing the installation time.

Ⓢ Everlux® project maritime is available in two different versions: version 2.5 and version 2.5i. In terms of hardware both versions can be used with 64 bit processors. The 2.5 version works on AutoCAD (post 2008 versions except AutoCAD LT) and after its installation will automatically generate a tool bar with the Ⓢ Everlux® project maritime menu.

The 2.5i version is an independent application that allows the use of image files (type *.dxf; *.jpg; *.bmp; *.png) as the basis for the safety signage project.

Ⓢ Everlux® project maritime is available for free download at: www.everluxmaritime.com/en/downloads

Quick life-safety and fire control plan development

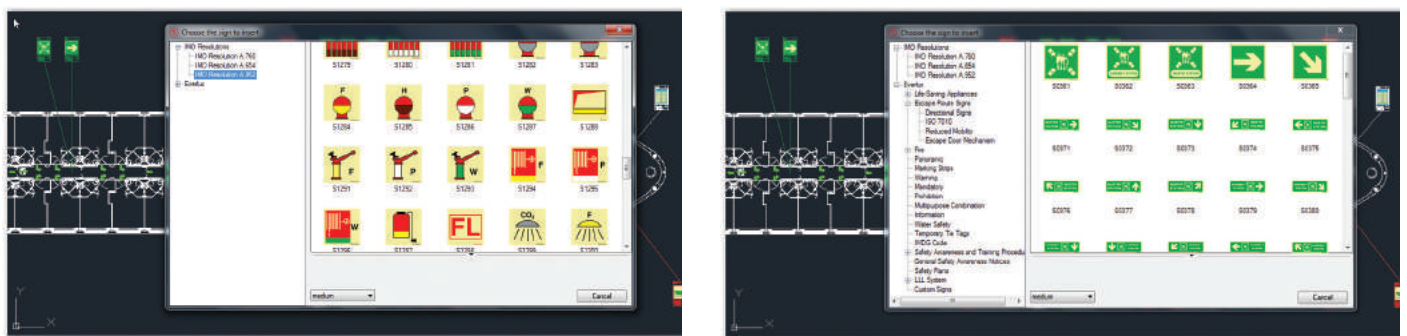

Quick Low Location Lighting project development and automated BOQ creation

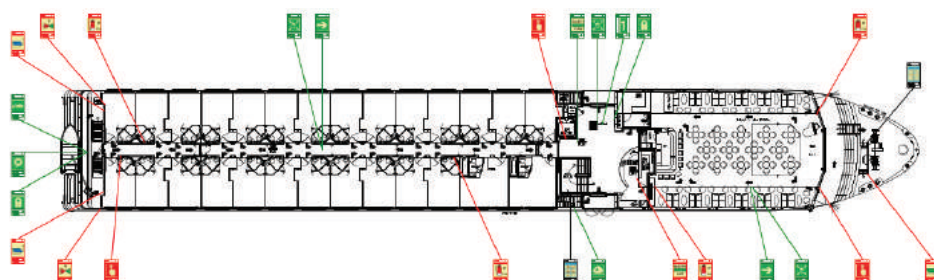



Low Location Lighting

Signs for wall marking at floor level

(mm)
107x57
158x83



The signs featured in this page can be supplied in photoluminescent rigid plastic, self-adhesive photoluminescent vinyl and transparent self-adhesive vinyl signs. The transparent self-adhesive vinyl signs are a quick solution to complement Low Location Lighting systems by applying them directly on to the photoluminescent strips.



S 20 03



S 20 04



S 20 05



S 20 06



S 20 07



S 20 08



S 20 09



S 20 10



S 20 01



S 20 02

Escape route signs with symbols according to ISO 7010 and BS 5499

(mm)
57x57
83x83



S 20 21



S 20 22



S 20 23



S 20 24



S 20 25



S 20 26



S 20 27



S 20 28



S 20 29

(mm)
57x57
83x83



S 20 41



S 20 42



S 20 43



S 20 44



S 20 45



S 20 46



S 20 47



S 20 48



S 20 49



S 20 50



S 20 51



S 20 52



S 20 53



S 20 54



S 20 55



S 20 56



S 20 57



S 20 58

(mm)
107x57
158x83



S 20 61

(mm)
107x57
158x83



S 20 65



S 20 66



S 20 67

(mm)
57x200
83x300



S 20 71



S 20 72

(mm)
57x57
83x83



S 20 81



S 20 82

Strips for wall marking at floor level







 (mm)
 1000x35
 1000x57
 1000x83

S 21 01
 S 21 02
 S 21 03

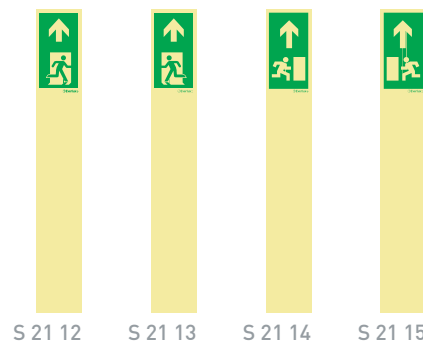
Marking strips for walls and stair risers

 (mm)
 1000x57
 1000x83

S 21 12
 S 21 13
 S 21 14
 S 21 15

Strips to identify doorways



(mm)
 2000x35
 2000x57
 2000x83

S 21 22

Rolls for wall marking

The  Everlux[®] photoluminescent vinyl rolls can be used in wall mounted LLL systems and are the ideal solution for applications in irregular or rounded walls. This product can also be used for emergency equipment marking and handrail identification.

 length (m)
 10



width (mm)
 35
 57
 83

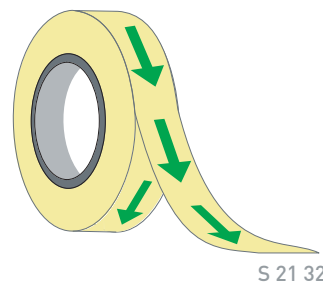
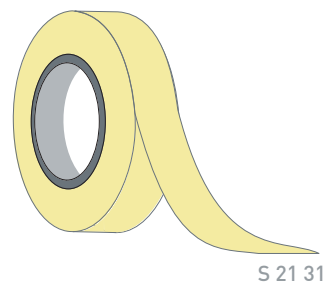



Low Location Lighting

System for floor and stair marking

(mm)
1200x37
1200x57
1200x83

S 21 51

S 21 52

S 21 53

Non-slip self-adhesive marking strips S 21 54

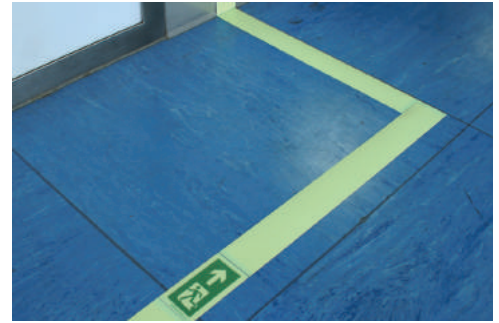

(mm)
107x57
158x83

Non-slip self-adhesive signs

S 21 61

S 21 62

S 21 65

S 21 66

Ⓢ Everlux®-LLL discs

S 21 75

S 21 76

60mm x 60mm

Discs for mesh metal floors (1 box of 12 units)

S 21 77

S 21 78

60mm x 1.7mm

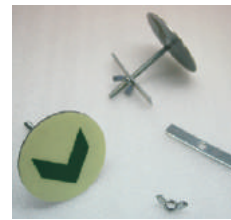

(mm)
Ø60
Ø100

S 21 79

S 21 80

60mm x 0.62mm

Non-slip self-adhesive discs for floors.
Ø60 - 1 sheet of 18 units.
Ø100 - sold by the unit.

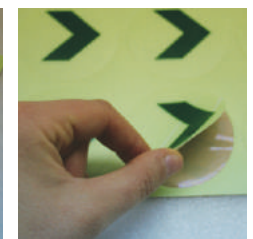

Ⓢ Everlux®-LLL Footprint silhouettes

Photoluminescent footprint silhouettes are ideal for indicating the direction and outline of evacuation routes. Available in left and right silhouettes to be used alternately, Ⓢ Everlux®-LLL Footprint Silhouettes are made from self-adhesive, anti-slip polycarbonate which is only 0.03mm thick.

220mm x 88mm

S 21 84





Non-slip self-adhesive “L” for stairs

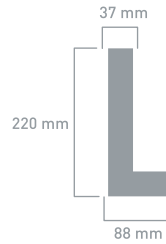

S 21 85

Designed to mark the edges of the steps. Supplied in sheets of 4 units (two signs per step)

In every flight of steps, the limits of the first and the final steps should be fully signed. You should use the strips code S 21 51

Stairnosing - protection for steps

Aluminium framework developed for stair nosing protection. This product has anti-slip properties, even in situations where oil has been spilt, due to the grooves featured over the whole surface.

On the upper and front parts there are Everlux²-LLL photoluminescent polycarbonate strips which also have anti-slip properties. These allow the perfect identification of the edge of the steps during a descending or ascending evacuation.

Properties

Materials: Aluminium and Everlux²-LLL in 0.3mm thick polycarbonate.

Sizes: Please refer to the technical drawings.

The Everlux² protection for steps is supplied with double-sided high adherence adhesive which allows an easy application.

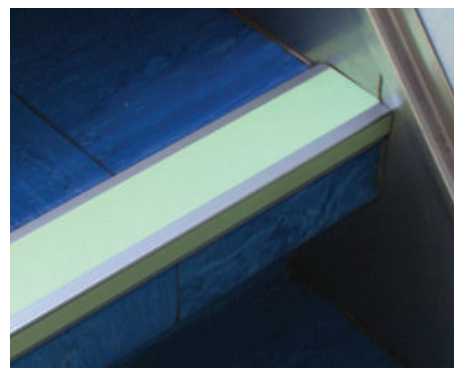
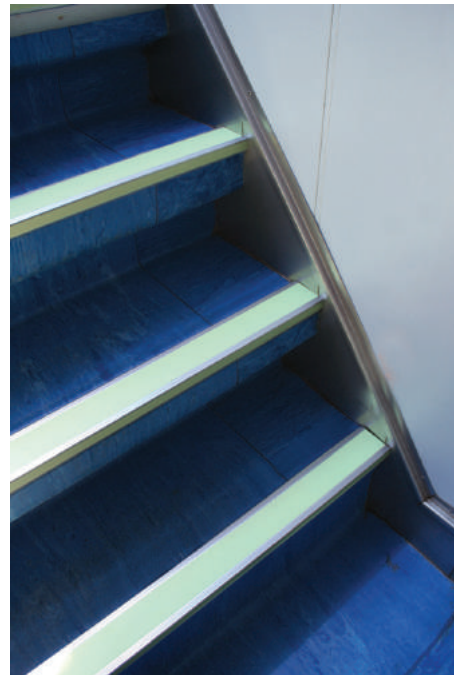
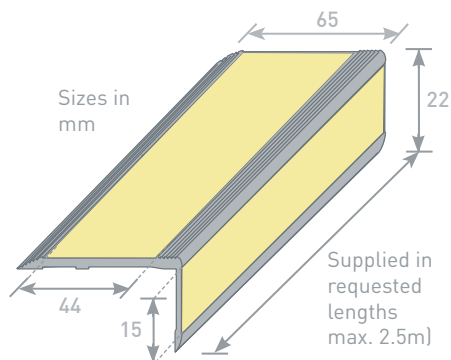

Protection for steps

S 21 90

Join the frame at two points, as in scheme 1, then rotate towards the riser until it is firmly adhered (scheme 2).

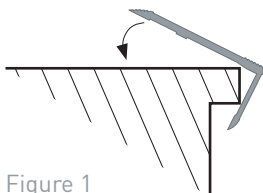

Figure 1

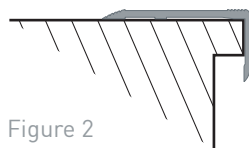

Figure 2

Panoramic signs

Fire equipment and evacuation

(mm)
100x100(*)
150x150
300x300

(*) Also available
in this size



S 25 01



S 25 02



S 25 03



(*) S 25 11



S 25 12

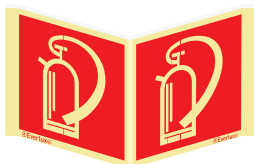

S 25 13



S 25 14



S 25 15

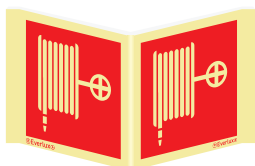

S 25 16



(*) S 25 17



S 25 18



S 25 19

(mm)
150x200
200x300
300x400



S 25 61



S 25 71



S 25 72



S 25 73



S 25 74

(mm)
100x200
150x300
200x400



S 26 01

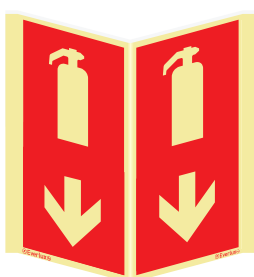

S 26 02

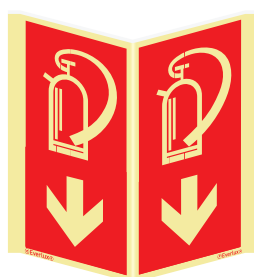

S 26 03



S 26 04

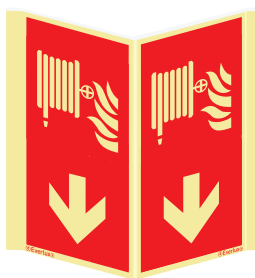

S 26 06

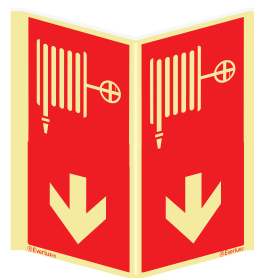

S 26 07

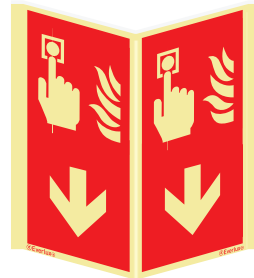

S 26 08

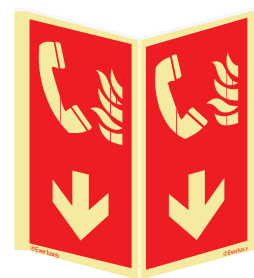

S 26 09



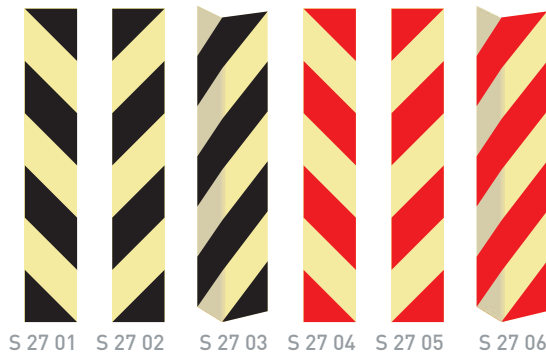
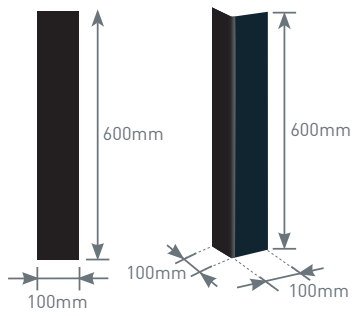

Photoluminescent marking strips to sign dangerous areas



Recommended for areas where people circulate. Specially for the signing of machines, pillars, corners, low-level fixed or protruding objects, dangerous areas, etc

To highlight obstacles, dangerous places and safe areas

As referenced in ISO 24409-1, ISO 384-1 specifies the following colour combinations for the layout of safety markings:

-  To indicate the location of hazards, e.g. obstacles or changes of level, or slippery surfaces.
-  To indicate prohibited areas or the location of fire fighting equipment.
-  To indicate safe areas or the location of emergency equipment.
-  To indicate mandatory instructions - e.g. "keep clear".
-  To identify the exact location of fire fighting equipment (effective alternative but not included in ISO 3864-1).



(mm)
1000x35
1000x57
1000x83

Photoluminescent rigid plastic strips

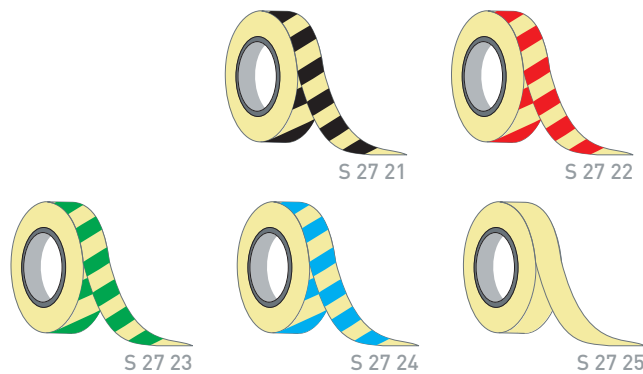
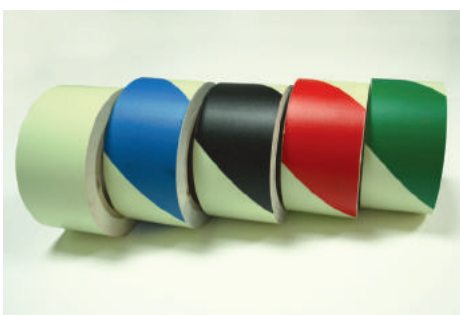

length (m)
10
width (mm)
35
57
83

Photoluminescent self adhesive vinyl

Self-adhesive reflective hazard warning strips to sign obstacles

Recommended for vehicle circulation areas to mark obstacles such as pillars and maximum height restrictions.

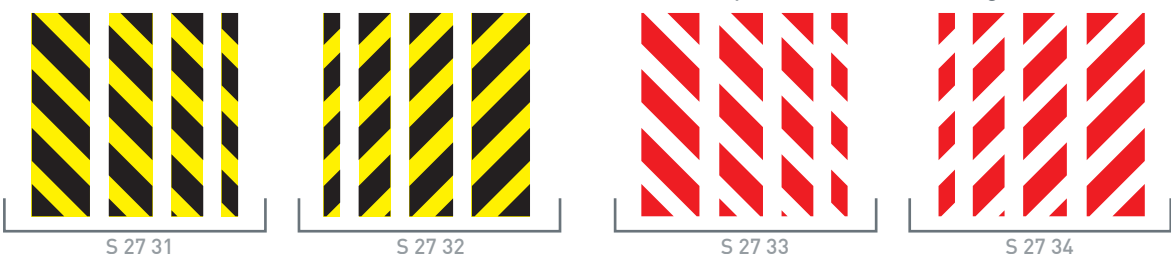

(mm)
680x50
680x100
680x150
680x200

Warning signs

General warning signs

(mm)

100x100

150x150

200x200

300x300(*)

(*) Also available

in this size



(mm)

300x100

400x150



General warning signs



(mm)
100x100
150x150
200x200
[*]300x300

[*] Also available
in this size

[*] S 31 01

S 31 02

S 31 03

S 31 04

S 31 05

S 31 06

S 31 07

[*] S 31 08

S 31 09

S 31 10

S 31 11

S 31 12

S 31 13

S 31 14



(mm)
300x100
400x150

S 31 51

S 31 52

S 31 53

S 31 54

S 31 55

S 31 56

S 31 57

S 31 58

S 31 59

S 31 60

S 31 61

S 31 62

S 31 63

S 31 64

S 31 87

S 31 65

S 31 66

S 31 67

S 31 68

S 31 69

S 31 70

S 31 71

S 31 72

S 31 73

S 31 74

S 31 75

S 31 76

S 31 88

S 31 89

S 31 90

S 31 77

S 31 78

S 31 79

S 31 80

S 31 91

S 31 92

S 31 93

S 31 94

S 31 95

S 31 96

S 31 97

S 31 98

S 32 02

Warning signs

General warning signs

(mm)
300x100
400x150



Deck, engine room and galley warning signs

(mm)
100x100
150x150
200x200



(mm)
300x100
400x150



Accommodation warning signs

(mm)
300x100
400x150



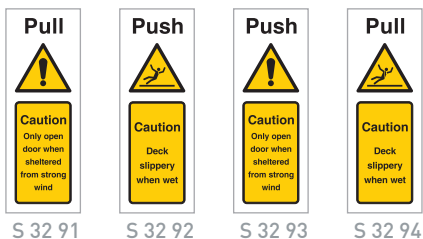

(mm)
73x200



Accommodation signs are only available in white rigid plastic and white self-adhesive vinyl

Fire and watertight door signs

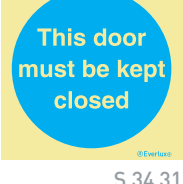
						(mm)
						(*)80x80
S 34 01	S 34 02	S 34 03				100x100
						150x150
						200x200
						(**)300x300
						[*],[**] Also available in this size
						
S 34 04	S 34 05	S 34 06	S 34 07	S 34 08		
						
S 34 09	S 34 10	S 34 11	S 34 12	S 34 13		
						
[*] S 34 14	[**] S 34 15	[**] S 34 16	[**] S 34 17	S 34 18		
						
S 34 19	[**] S 34 20	S 34 21	S 34 22	S 34 23		
						
S 34 24	S 34 25	S 34 26	S 34 27	S 34 28		
						
[**] S 34 29	S 34 30	S 34 31	S 34 32	S 34 33		
						
S 34 34	S 34 35	S 34 36	S 34 37	S 34 38		
						To prevent the obstruction of escape routes, mandatory signs should be permanently fixed on all fire and watertight doors

! Mandatory signs

Personal protective equipment signs



(mm)
100x100
150x150
200x200
300x300(*)

(*) Also available
in this size

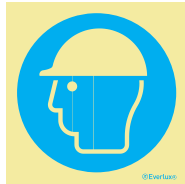

(*) S 35 01



(*) S 35 02



(*) S 35 03

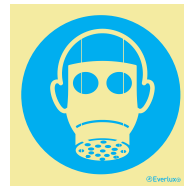

(*) S 35 04

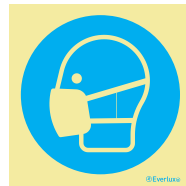

(*) S 35 05



(*) S 35 06



(*) S 35 07



S 35 08

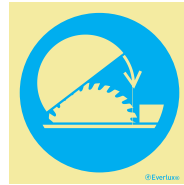

S 35 09



S 35 10



S 35 11

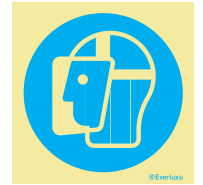

S 35 12



(*) S 35 13



S 35 14

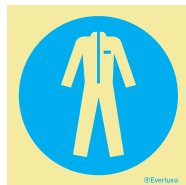

(*) S 35 15

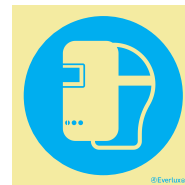

(*) S 35 16

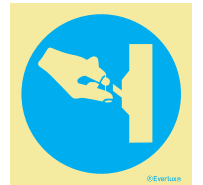

S 35 17



(*) S 35 18

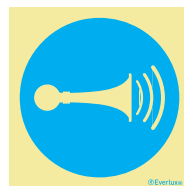

S 35 19



S 35 20

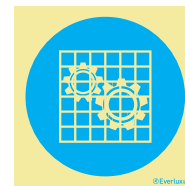

S 35 21

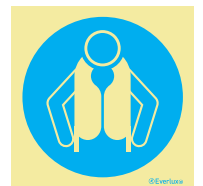

S 35 22

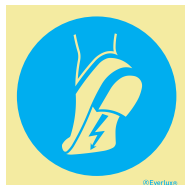

S 35 23



S 35 24



S 35 25



S 35 26



S 35 27

Personal protective equipment signs

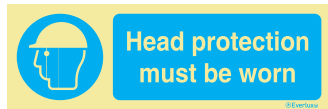

(*) S 35 51

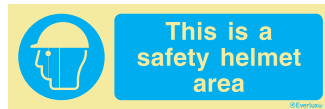

S 35 52

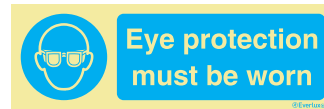

(*) S 35 53

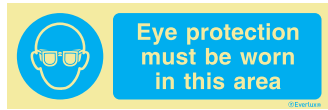

(*) S 35 54

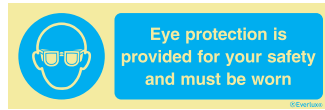

S 35 60

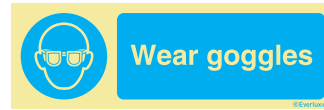

S 35 61

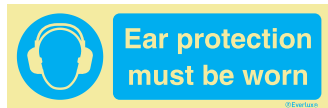

(*) S 35 55

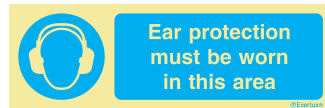

S 35 62

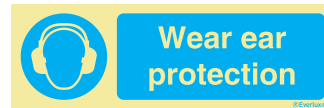

S 35 63

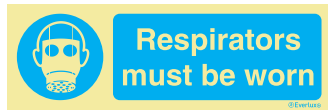

S 35 56

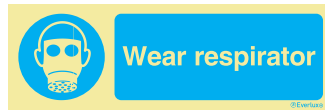

S 35 64

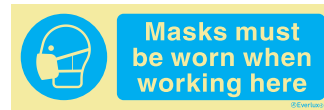

(*) S 35 57



(*) S 35 58

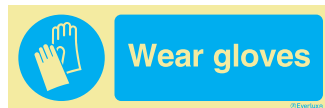

S 35 65

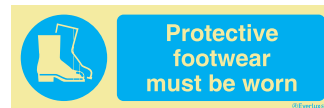

(*) S 35 59



(*) S 35 66



S 35 71

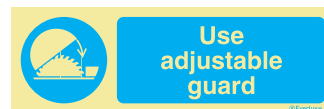

S 35 72

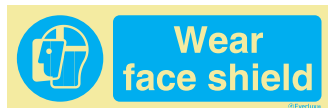

S 35 73

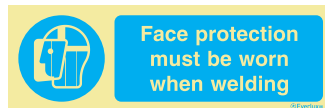

S 35 86

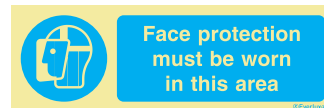

S 35 87

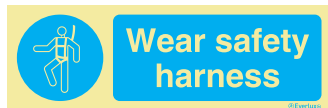

S 35 74



S 35 75

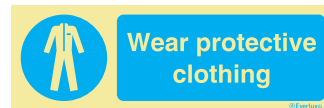

(*) S 35 76

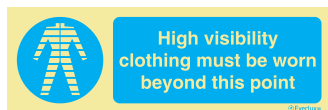

S 35 77

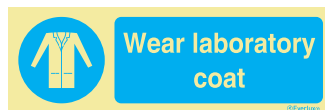

S 35 78



(*) S 35 79



S 35 80



(*) S 35 81



S 35 82

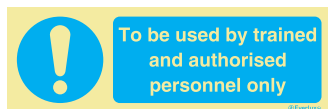

S 35 83



S 35 88



S 35 67



S 35 68

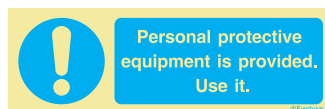

S 35 69

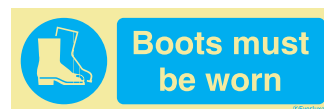

S 35 70

(mm)
300x100
400x150
(*)600x200

(*) Also available in this size

To ensure the correct use of protective wear, mandatory signs must be used. Mandatory actions must be marked with mandatory signs

! Mandatory signs

Personal protective equipment signs

(mm)
300x100
400x150



S 35 89

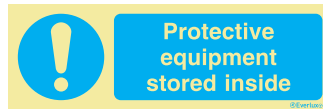

S 35 90



S 35 91

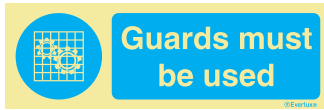

S 35 84

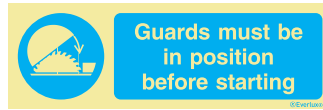

S 35 92



S 35 85

ISPS Code mandatory signs

(mm)
300x100
400x150



S 36 01

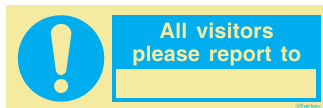

S 36 02



S 36 03



S 36 04



S 36 05

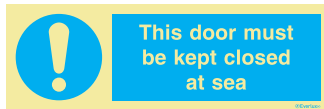

S 36 06

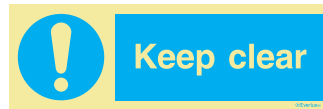

S 36 07

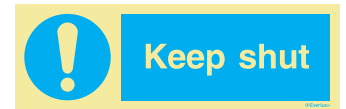

S 36 08

Deck and engine room mandatory signs

(mm)
300x100
400x150



S 36 11



S 36 12

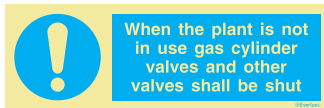

S 36 13

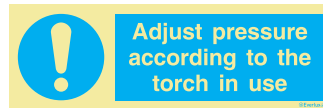

S 36 14

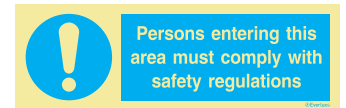

S 36 16

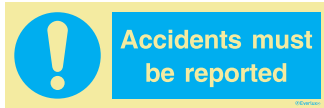

S 36 17

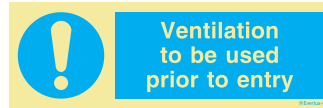

S 36 18

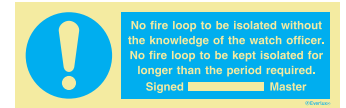

S 36 19

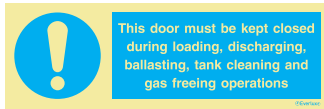

S 36 20

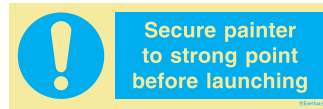

S 36 21



S 36 22

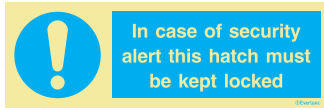

S 35 93



S 35 94



S 35 95

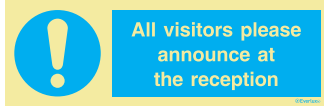

S 35 96

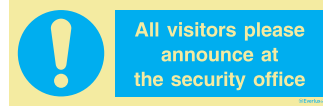

S 35 97

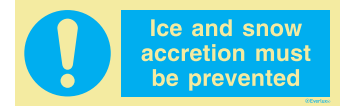

S 35 98

Prohibition signs

Signs to prohibit dangerous actions



(mm)
100x100
150x150
200x200
300x300(*)

(*) Also available
in this size



(*) S 38 01



(*) S 38 02



S 38 03



S 38 04



S 38 05



S 38 06



S 38 07



S 38 08

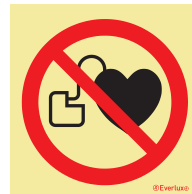

S 38 09



S 38 10



S 39 01



S 39 02



S 39 03



S 39 04



S 39 05



S 39 06



S 39 07



S 39 08



S 39 09



S 39 10



S 39 11



S 39 12



(*) S 39 13



S 39 14



S 39 15



S 39 16

Signs to prohibit dangerous actions

	 S 38 51	 S 38 52	 (mm) 300x100 400x150 (*)600x200 (*) Also available in this size
 S 38 53	 S 38 54	 S 38 55	
 S 38 56	 S 38 57	 S 38 73	
 S 38 74	 S 38 75	 (*) S 38 78	
 (*) S 38 59	 S 38 60	 S 38 61	
 S 38 62	 S 38 63	 S 38 64	
 S 38 65	 S 38 66	 S 38 67	
 S 38 68	 S 38 69	 S 38 70	
 S 38 71	 S 38 72	 S 38 76	Prohibiting dangerous behaviour limits potential risks

Prohibition signs

Signs to prohibit dangerous actions

(mm)
300x100
400x150



S 39 51

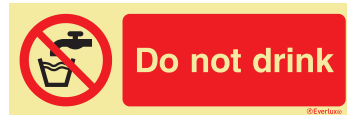

S 39 52



S 39 53

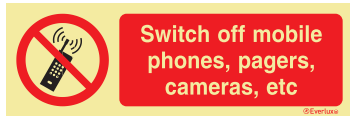

S 39 54

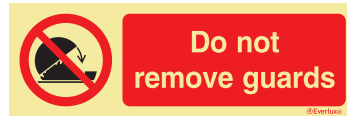

S 39 55



S 39 56



S 39 57



S 39 58



S 39 59



S 39 60



S 39 61



S 39 62



S 39 63



S 39 64



S 39 65



S 39 66

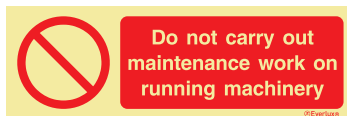

S 39 67



S 39 68

Prohibiting dangerous behaviour limits potential risks



S 39 69

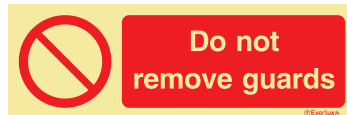

S 39 70

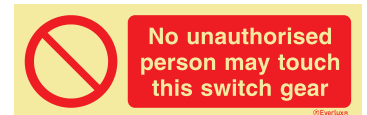

S 39 71

ISPS Code prohibition signs

(mm)
300x100
400x150

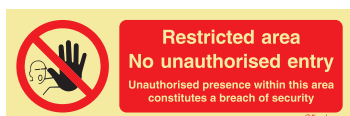

S 39 81

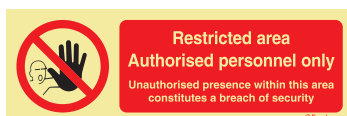

S 39 82



S 39 72



S 39 73



S 39 74



S 39 75



S 39 76

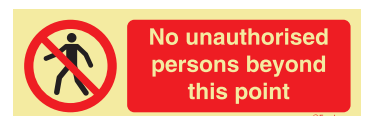

S 39 77



S 39 78









S 39 83



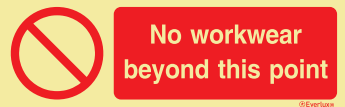



S 39 79

Prohibition signs

Deck and engine room prohibition signs

			 (mm) 300x100 400x150
	S 39 91	S 39 65	
			
S 38 57	S 38 65	S 39 95	

Galley prohibition signs

			 (mm) 300x100 400x150
		S 40 01	
			
S 40 02	S 40 03	S 40 04	

Accommodation prohibition signs

			 (mm) 300x100 400x150 [*]600x200
		[*] S 40 11	
			[*] Also available in this size
S 40 12	S 40 13	S 40 14	
			
S 40 15	S 40 17	S 40 16	
			These signs are only available in white rigid plastic and white self-adhesive vinyl
S 40 18	S 40 19	S 40 20	

Multipurpose combination signs

Multiple signage for danger, prohibition and obligation

(mm)
300x200



Danger
Explosion risk

In the event of fire remove bottles to safe area

S 40 51

Danger
Explosion risk

Important
Close all oxy/acetylene valves after each use

S 40 52

Warning
Gas under pressure

In case of fire remove cylinders to a safe place

S 40 53

Danger
Vehicle fumes

Ventilation to be in use at all times during cargo operations

S 40 54

Caution
Non-ionizing radiation

Secure radar, satcom and radio equipment before accessing the monkey Island

S 40 55

Danger
Keep out

S 40 56

Danger
Steep ladders

Descend backwards use both handrails

S 40 57

Danger
Gas

No fire
No open lights
No smoking

S 40 58

Danger
Petroleum spirit highly flammable

No smoking
No naked lights

S 40 59

Warning
The crude oil washing lines on this vessel may contain crude oil

No valves to be opened or work to be performed without the permission of the Chief Officer

S 40 60

Danger
Confined space

Do not enter without a permit to work

S 40 61

Danger
Asbestos

Do not disturb

S 40 62

Danger
Hazardous area

Do not enter

S 40 63

Do not throw garbage overboard

Use bins provided

S 40 64

No smoking
No naked lights

S 40 65

(mm)
300x400



Warning
Dangerous cargo

No visitors

No smoking
No naked lights

No mobile phones, pagers, or other electronic equipment to be turned on except in specified areas

International shore connection is located at: [Master]

S 40 71

Security Notice

Permit to board required. Visitors must report to the Security Officer on arrival and departure. Baggage and personal searches may be conducted.

No weapons, incendiary devices and explosives

No mobile phones, pagers, or other electronic equipment to be turned on except in specified areas

No photography

S 40 72

(mm)
300x300



Security notice

Authorised access only

No unauthorised weapons or photography

Legal action will be taken on any violations

S 40 73

Ship's security

In accordance with the ISPS Code all persons wishing to board this vessel must prove their identities upon request and should be prepared to be frisked

No unauthorised cameras, cellular phones or weapons

Any disagree to either of these procedures will result in refusal of entry

S 40 74

Ship's security

All visitors please announce at the reception

No cameras

No cellular phones

S 40 75

Ship's security

In accordance with the ISPS Code all persons wishing to board this vessel must prove their identities be prepared to be frisked for drugs and weapons.

Any disagree to either of these procedures will result in refusal of entry.

S 40 76

Multiple signage for danger, prohibition and obligation

Danger
Explosion risk

No smoking

No naked lights

No hot work
No chipping
No unapproved electrical equipment

(mm)
300x300

S 40 81

Refrigerated Space

Caution
Low temperature and slip hazard

No smoking

Wear hairnet at all times

(mm)
300x300

S 41 01

Battery Locker

Danger
Battery acid

No entry to unauthorised personnel
No smoking or naked lights

Minimum safety requirements:
Overalls
Face shield
Safety gloves

S 41 02

Galley

No smoking

Wash hands before preparing food

Minimum safety requirements:
Helmet
Safety footwear

S 41 03

Machinery Space

Caution
Space protected by gas flood system if alarm sounds vacate immediately
Machinery may start and stop without warning

No entry to unauthorised personnel
No smoking or naked lights except in designated areas

Minimum safety requirements:
Overalls
Head protection
Ear defenders
Safety boots

S 41 04

Gas Bottle Store

Danger
Compressed gases

No entry to unauthorised personnel
No smoking or naked lights

Keep well ventilated

S 41 05

Paint Store

Danger
Flammable liquid

No entry to unauthorised personnel
No smoking or naked lights

Keep well ventilated

S 41 06

Chemical Locker

Danger
Flammable liquid

No entry to unauthorised personnel
No smoking or naked lights

Keep well ventilated

S 41 07

Switch Gear

Danger
High voltage

No entry to unauthorised personnel
No smoking or naked lights

Minimum safety requirements:
Overalls
Safety gloves
Ear defenders
Safety boots

S 41 08

Forecastle Space

Caution
Space protected by gas flood system if alarm sounds vacate immediately
Machinery may start and stop without warning

No entry to unauthorised personnel
No smoking or naked lights

Minimum safety requirements:
Overalls
Head protection
Ear defenders
Safety boots

S 41 09

Fridge Machinery

Danger
Toxic fumes
Machinery may start without warning

No entry to unauthorised personnel
No smoking or naked lights

Keep well ventilated

S 41 10

Emergency Generator

Danger
High voltage
Machinery may start without warning

No entry to unauthorised personnel
No smoking or naked lights

Minimum safety requirements:
Overalls
Safety gloves
Ear defenders
Safety boots

S 41 11

Steering Gear

Danger
Moving machinery

No entry to unauthorised personnel
No smoking or naked lights

Minimum safety requirements:
Overalls
Head protection
Ear defenders
Safety boots

S 41 12

Pump Room

Caution
Confined space with moving machinery

No entry to unauthorised personnel
No smoking or naked lights

Minimum safety requirements:
Overalls
Head protection
Ear defenders
Safety boots

S 41 13

i Information signs

Safety signs according to the ICAO and IMO Document 9636

(mm)
150x150
200x200
300x300
400x400



The ICAO and IMO joint publication Document 9636 specifies the signs to provide guidance information to persons at airports and marine terminals.
The "First Aid", "No Smoking", "No Entry/No trespassing" and "Carry no weapons on board" signs should be designed according to the colours specified in Section II of this publication whilst the colours of general information signs can be decided by national or local authorities keeping in mind that readability is of the foremost importance.



S 42 01



S 42 02

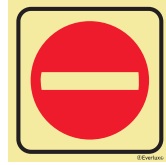

S 42 03



S 42 04

(mm)
150x150
200x200
300x300
400x400



S 42 51



S 42 52

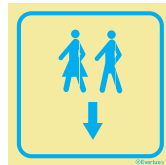

S 42 53

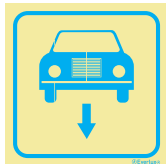

S 42 54



S 42 55

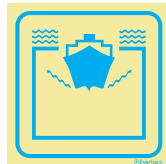

S 42 56

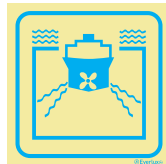

S 42 57



S 42 58



S 42 59



S 42 60



S 42 61



S 42 62



S 42 63



S 42 64



S 42 65



S 42 66



S 42 67



S 42 68



S 42 69

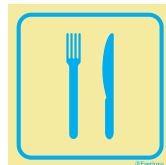

S 42 70



S 42 71



S 42 72



S 42 73



S 42 74



S 42 75

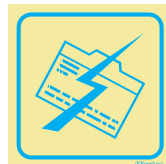

S 42 76



S 42 77

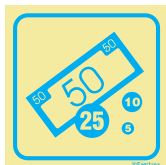

S 42 78



S 42 79

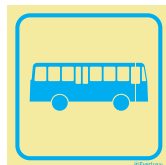

S 42 80

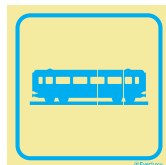

S 42 81

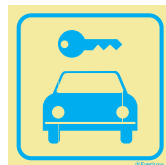

S 42 82



S 42 83

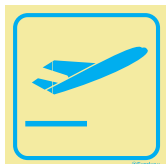

S 42 84



S 42 85



S 42 86

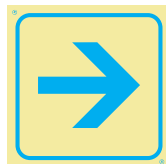

S 42 87



S 42 88



S 42 89

Security Level signs

The  Everlux® Security Level signs are available in a photoluminescent magnetic finish. This is the ideal solution to secure adhesion to all suitable metallic surfaces. The magnetic finish also allows for the quick and easy change of security level indicator. The selling unit of this product is comprised of 4 components.

 (mm)
200x180



S 42 10



S 42 11



S 42 12



S 42 13

 (mm)
200x100

Crew only access

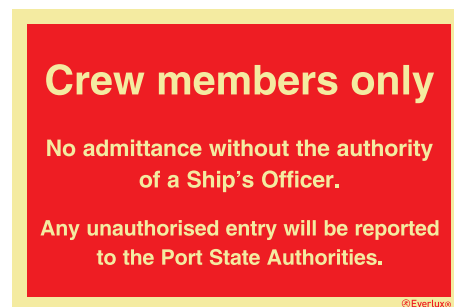

S 42 20

 (mm)
300x200

Ultra-destructible seals



[*] S 42 25

 (mm)
[*] 150x30
 (**) 300x30



[**] S 42 26

[*] [**] Only available in this size



[*] S 42 27

Only available in non-photoluminescent ultra-destructible self-adhesive vinyl. Detailed technical sheet available on request.

ISPS Code signs

ISPS compliant notices

(mm)
900x450



THIS SHIP COMPLIES WITH THE
I.M.O. ISPS CODE

STRICT SECURITY MEASURES & PROCEDURES ARE ENFORCED
NO OFFENSIVE WEAPONS ALLOWED

VISITORS WILL BE MET ON DECK AND MUST REGISTER ONBOARD WITH
A PHOTOGRAPHIC IDENTIFICATION DOCUMENT AND MAY BE SUBJECT
TO PERSONAL OR BAGGAGE SEARCHES

YOUR CO-OPERATION IS EXPECTED IN COMPLIANCE WITH MARITIME
SECURITY REQUIREMENTS

THE MASTER

S 42 30

(mm)
300x200



RESTRICTED AREA

AUTHORIZED

PERSONNEL ONLY

UNAUTHORIZED PRESENCE WITHIN THIS AREA
CONSTITUTES A BREACH OF SECURITY

©Everlux

S 42 31

CCTV signs

(mm)
150x150[*]
200x300[**]



[*] [**] Only
available in this size

**This vessel
is under**

CCTV

Surveillance

[**] S 42 40

CCTV

In operation

[*] S 42 41

VDR

**Voice recording is
fitted on this bridge**

[*] S 42 42

(mm)
300x100



24 h

**This area is
under CCTV
surveillance**

©Everlux

S 42 43



excellence by Evertex safety signs for super yachts



excellence by Evertex is a safety signage solution that creates an harmonious co-existence between the sign elements and the upscale environment, emphasising on the aesthetics and decorative style of the vessels. The structure of every excellence by Evertex sign is comprised of top quality and innovative materials. This sign range is distinct from other safety signs as the use of coloured pigments allows both the pictogram and the background colours to be visible in the dark. excellence by Evertex is a patented product.

(mm)
60x60

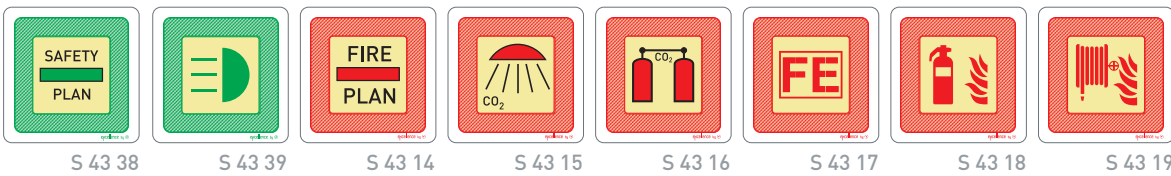
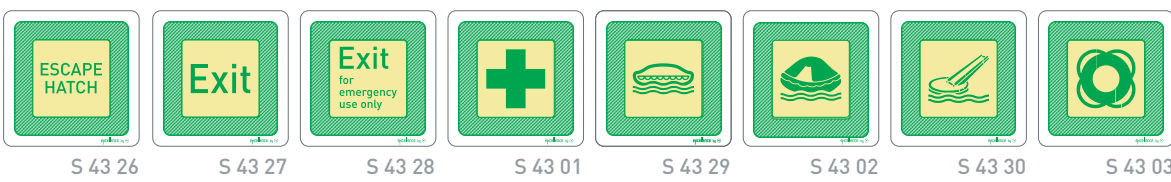
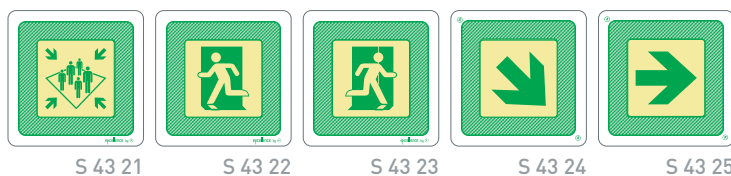
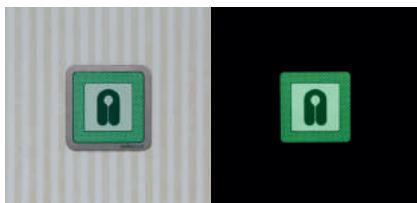

Safety signs for super yachts

Life-saving appliances, fire, mandatory and prohibition signs

(mm)
50x50

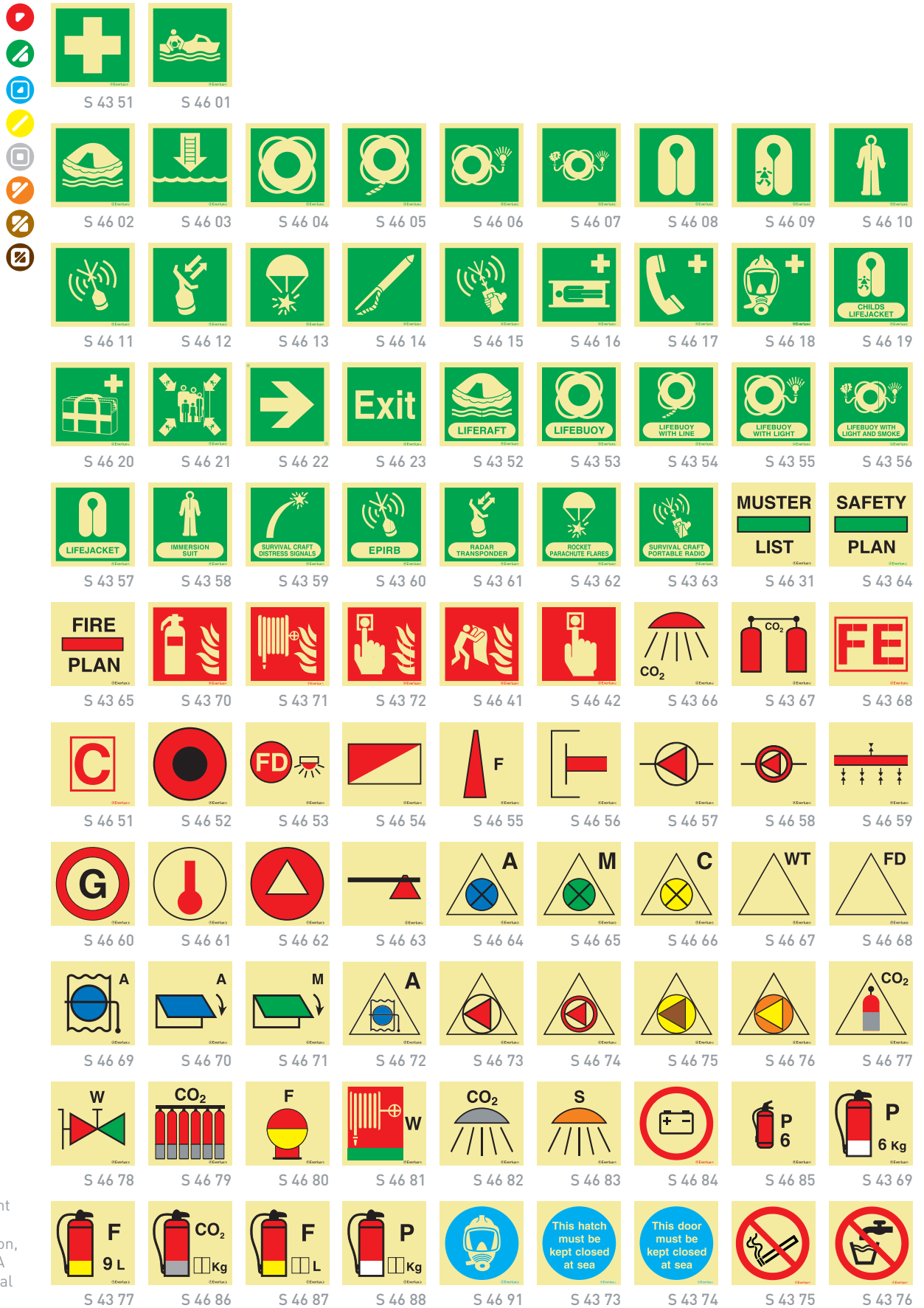

Photoluminescent safety signs, in smaller dimension, according to MCA Large Commercial Yacht Code (LY3).

(mm)
150x50





The Offshore Wind Industry has significantly expanded in the recent past. This is a unique industry with specific structures and vessels where service technicians and crews face equally unique hazards. The Everlux photoluminescent safety signs for the Offshore Wind Industry are the ideal solution to identify them.

Warning signs

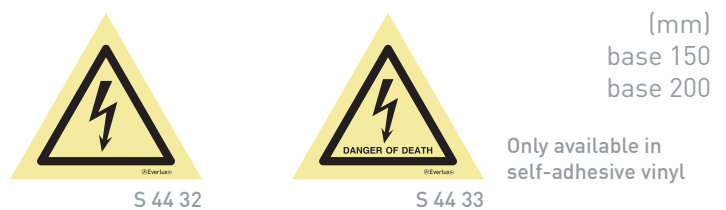
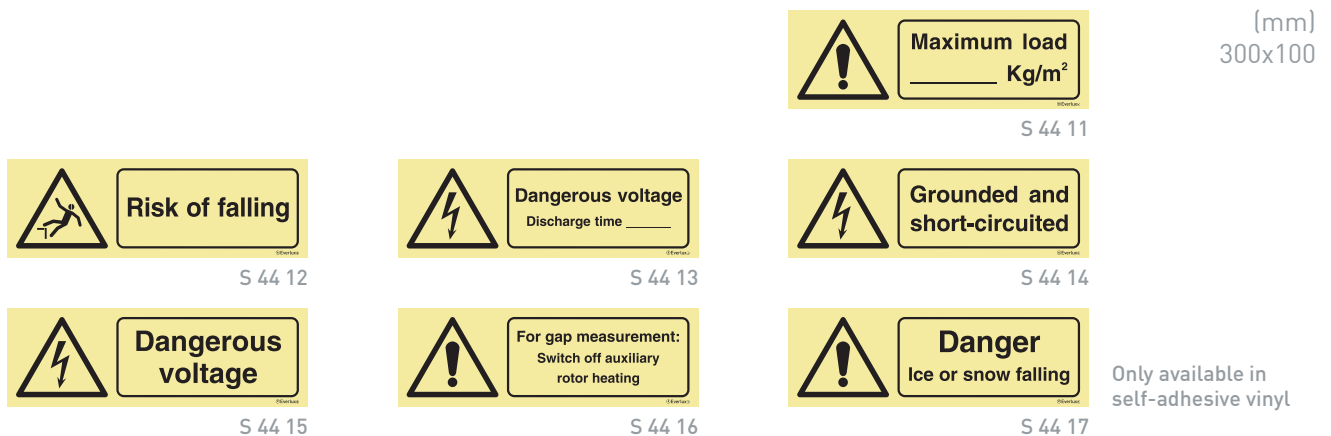

Offshore wind - safety signs

Prohibition signs

(mm)
Diam. 80

Self-adhesive sign
supplied in sheets
of 12 units

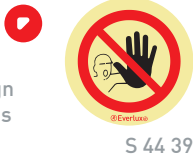

(mm)
300x100

Only available in
self-adhesive vinyl

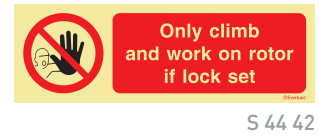

(mm)
200x200

Magnetic sign



Mandatory and personal protective equipments signs

(mm)
Diam. 80

Self-adhesive signs
supplied in sheets of
12 units



(mm)
300x100

Only available in
self-adhesive vinyl



Signs for manually operated devices

(mm)
150x150
200x150(*)

(*) Only available
in this size

Only available in
self-adhesive vinyl

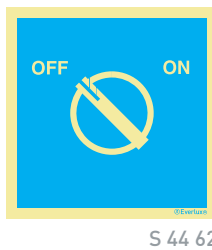
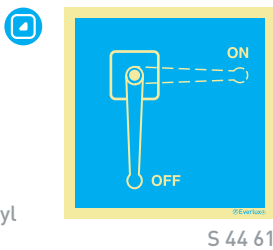

Emergency, fire and prohibition signs

(mm)
150x150
200x200
300x300
400x400
600x600



Safety procedures

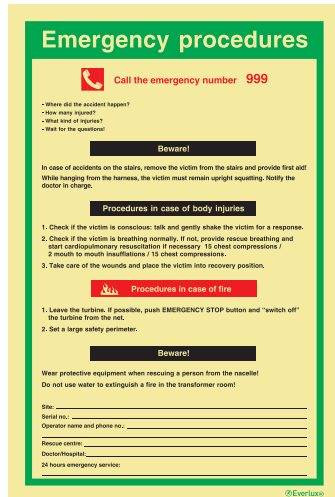

S 44 70

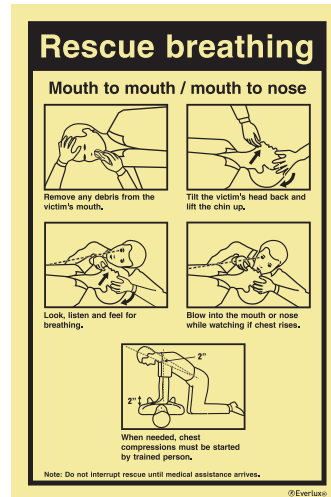

S 44 77

(mm)
200x300



Only available in self-adhesive vinyl



(*) S 44 76

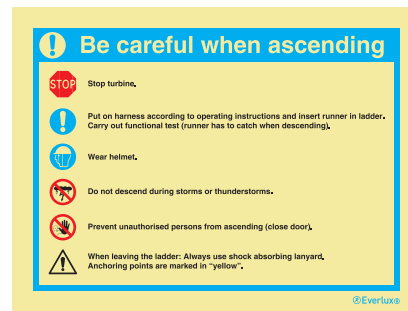

S 44 77

(mm)
200x150
(*)200x300

(*) Only available in this size

Only available in self-adhesive vinyl

Offshore wind - safety signs bilingual cross reference table

Supplementary texts in the following languages:			
EN	NO - EN	NL - EN	ES - EN
S4411	S4418	S4425	S4405
S4412	S4419	S4426	S4406
S4413	S4420	S4427	S4407
S4414	S4421	S4428	S4482
S4415	S4422	S4429	S4483
S4416	S4423	S4430	S4484
S4417	S4424	S4431	S4485
S4433	S4434	S4435	S4486
S4436	S4437	S4438	S4487
S4440	S4443	S4446	S4488
S4441	S4444	S4447	S4489
S4442	S4445	S4448	S4490
S4449	S4450	S4451	S4491
S4458	S4459	S4460	S4492
S4461	S4464	S4467	S4493
S4462	S4465	S4468	S4494
S4463	S4466	S4469	S4495
S4470	S4471	S4472	S4496
S4473	S4474	S4475	S4497
S4476	S4478	S4480	S4498
S4477	S4479	S4481	S4499

The ©Everlux® safety signs for the Offshore Wind Industry are available in several bilingual supplementary text options: NO - EN, NL - EN and ES - EN. If you wish to order these signs in any of the bilingual options please refer to the item code cross reference table and use the respective sign code in your purchase order.

Safety signs for water parks, swimming pools and beaches



Safety signage in water parks is very important due to the increase in the number of these infra-structures as well as the related number of serious accidents occurring in these areas. Safety signs should be used in water activity areas in order to alert its users to the rules in place and to any potential hazards, thereby consequently prevent dangerous behaviour. These signs are in compliance with ISO 20712-1 and BS 5499-11.

Our water safety signs are manufactured in 3mm thick white aluminium composite material and feature an anti-graffiti protective clear film. This film also provides signs with effective protection for outdoor installations, humid environments or in the presence of water containing a strong acid or alkaline content (eg: lime and chlorine).

Prohibition signs

(mm)

200x200

300x300

400x400(*)

(*) Also available
in this size



(*) S 45 01



(*) S 45 02



(*) S 45 03



(*) S 45 04



S 45 05



(*) S 45 06



(*) S 45 07



(*) S 45 08



(*) S 45 09



(*) S 45 10



S 45 11



(*) S 45 12



(*) S 45 13



S 45 14



S 45 15



(*) S 45 16



(*) S 45 17



S 45 18



S 45 19



S 45 20



S 45 21





Warning signs

 (mm)
 (*) 200x200
 300x300
 (*) Also available in this size

					
S 45 51	S 45 52	S 45 53	S 45 54		
					
S 45 55	S 45 56	S 45 57	S 45 58	S 45 59	S 45 60
					
S 45 61	S 45 62	S 45 63	(*) S 45 64	S 45 65	S 45 66
					
S 45 67	S 45 68	S 45 69	S 45 70	S 45 71	S 45 73

Mandatory signs





 (mm)
 200x200
 300x300

	
S 45 81	S 45 82
	
S 45 83	S 45 84



Information signs

 (mm)
 200x200
 300x300
 (*) 400x400
 (*) Also available in this size

			
S 45 91	(*) S 45 92	S 45 93	S 45 94

Temporary tie tags



Warning sign tags

(mm)
75x150



All the EverLux® tie tags have a clear protective film which provides them with a rewritable feature

Prohibition sign tags

(mm)
75x150



Mandatory sign tags

(mm)
75x150



Anti-splashing tape



Anti-Splashing Tape Model N° 888FN was designed to protect pipeline installations against leakage and splashing of fuel oil, lube oil and other flammable oils. This tape is used for applications in the marine and offshore industries in screening of pipe joints, valves and fittings in accordance with SOLAS Consolidated Edition, 2004, Chapter II-2/Regulations 4, item 2.2.5.3.

The Anti-Splashing Tape Model N° 888FN is available in tape format of various sizes versions and an adhesive agent is applied on one side and covered by separator film to ensure easy installation.

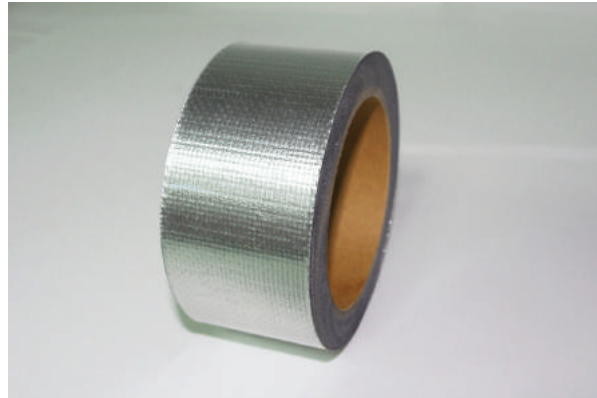

Tape components:

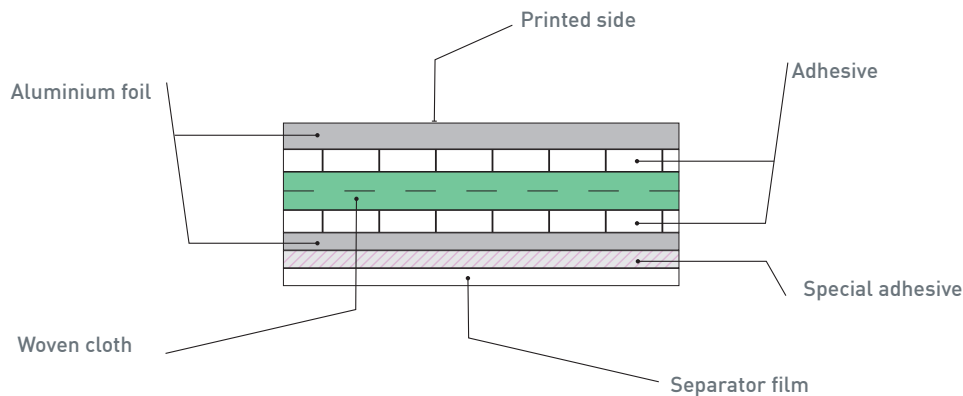

Aluminium foils are superimposed on both sides of the glass woven cloth together with a special acrylic adhesive agent to form a laminate structure.

The tape has the ship classification societies' logos printed on its surface to ensure the market of its full compliance with SOLAS regulations.

Specification of tape ¹	
For use:	On pipes and joints for heavy fuel oil
Maximum temperature:	424° K (150 °C)
Maximum pressure:	3.0 MPa (30 bar)
Approved pressure:	1.5 MPa (15 bar)

Availability	
Reference:	Size (Width x Length) /Roll
S 51 00	25mm x 10m
S 51 01	35mm x 10m
S 51 02	50mm x 10m
S 51 03	100mm x 10m
S 51 04	140mm x 10m
S 51 05	250mm x 10m
S 51 06	500mm x 10m

¹ Reference - Details of approval by Lloyd's Register(LR)

Pipe content identification

Pipe identification colour-coded tape according to ISO 14726:2008 and NORSOK L-004



length (m)
25

width (mm)
50



The Everlux® marking solution for piping systems is available in single colour and in multiple colour self-adhesive vinyl rolls.



The single colour (main colours which indicate a group of similar media) rolls can be combined in order to attain the colour coding that identifies specific contents.



The multiple colour rolls are available with the different colour combinations for every specific pipe content and are the ideal solution to save installation time.



The Everlux® marking solutions for pipe content identification are compliant with ISO 14726: 2008 and NORSOK L-004.



Medium	Colour	Item code
Waste media	Black	S 50 01
Fresh water	Blue	S 50 02
Fuel	Brown	S 50 03
Sea water	Green	S 50 04
Non-flammable gases	Grey	S 50 05
Air and sounding pipes	Maroon	S 50 06
Oils other than fuels	Orange	S 50 07
Steam	Silver	S 50 08
Fire fighting	Red	S 50 09
Acids, alkalis	Violet	S 50 10
Air in ventilation systems	White	S 50 11
Flammable gases	Yellow	S 50 12
Flow arrows	-	S 50 00

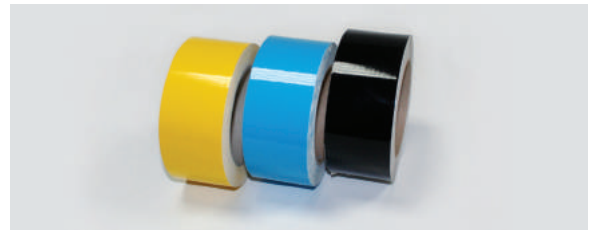

These self-adhesive vinyl rolls can be combined (additional colour) in order to attain the colour coding that identifies each specific content.

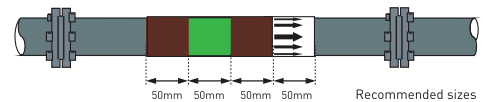

Installation Points: Pipelines should be marked at least once in each room; at each penetration point in bulkheads, walls and decks; close to each valve; within a distance of 3m to 5m of the length of the pipeline whereby local conditions may require more marking due to pipe bends or the close proximity of pipes for different services.

Waste Media	Colours	Item codes
Black water	Black/Blue	S 50 01 - S 50 02 - S 50 01
Waste oil/used oil	Black/Brown	S 50 01 - S 50 03 - S 50 01
Bilge water	Black/Green	S 50 01 - S 50 04 - S 50 01
Exhaust gas	Black/Grey	S 50 01 - S 50 05 - S 50 01
Grey water	Black/White	S 50 01 - S 50 11 - S 50 01
Sewage, contaminated	Black/Yellow	S 50 01 - S 50 12 - S 50 01

Fresh Water	Colours	Item codes
Fresh water, sanitary	Blue/Brown	S 50 02 - S 50 03 - S 50 02
Potable water	Blue/Green	S 50 02 - S 50 04 - S 50 02
Distillate	Blue/Grey	S 50 02 - S 50 05 - S 50 02
Gas-turbine wash water	Blue/Orange	S 50 02 - S 50 07 - S 50 02
Feed water	Blue/Silver	S 50 02 - S 50 08 - S 50 02
Cooling fresh water	Blue/Violet	S 50 02 - S 50 10 - S 50 02
Chilled water	Blue/White	S 50 02 - S 50 11 - S 50 02
Condensate	Blue/Yellow	S 50 02 - S 50 12 - S 50 02

Fuel	Colours	Item codes
Heavy fuel oil (HFO)	Brown/Black	S 50 03 - S 50 01 - S 50 03
Aviation fuel	Brown/Blue	S 50 03 - S 50 02 - S 50 03
Biological fuel	Brown/Violet	S 50 03 - S 50 10 - S 50 03
Gas-turbine fuel	Brown/White	S 50 03 - S 50 11 - S 50 03
Marine diesel oil (MDO)	Brown/Yellow	S 50 03 - S 50 12 - S 50 03

Flow arrows	Colours	Item codes
Flow arrows	White/Black	S 50 00

Sea water	Colours	Item codes
Decontamination water	Green/Blue	S 50 04 - S 50 02 - S 50 04
Sea water, sanitary	Green/Brown	S 50 04 - S 50 03 - S 50 04
Ballast water	Green/Violet	S 50 04 - S 50 10 - S 50 04
Cooling sea water	Green/Yellow	S 50 04 - S 50 12 - S 50 04

Non-flammable gases	Colours	Item codes
Oxygen	Grey/Blue	S 50 05 - S 50 02 - S 50 05
Inert gas	Grey/Brown	S 50 05 - S 50 03 - S 50 05
Nitrogen	Grey/Green	S 50 05 - S 50 04 - S 50 05
Refrigerant	Grey/Orange	S 50 05 - S 50 06 - S 50 05
Compressed air LP (Low pressure)	Grey/Orange	S 50 05 - S 50 07 - S 50 05
Compressed air HP (High pressure)	Grey/Red	S 50 05 - S 50 09 - S 50 05
Control air/regulating air	Grey/Violet	S 50 05 - S 50 10 - S 50 05
Breathing air*	Grey/White	S 50 05 - S 50 11 - S 50 05
Breathing gas*	Grey/Yellow	S 50 05 - S 50 12 - S 50 05

* This marking is used in submarines for distribution systems of breathing air from cylinders.

Fire fighting/ fire protection	Colours	Item codes
Fire-fighting water	Red/Green	S 50 09 - S 50 04 - S 50 09
Fire-fighting gas	Red/Grey	S 50 09 - S 50 05 - S 50 09
Sprinkler water	Red/Orange	S 50 09 - S 50 07 - S 50 09
Spray water	Red/Violet	S 50 09 - S 50 10 - S 50 09
Fire-fighting powder	Red/White	S 50 09 - S 50 11 - S 50 09
Fire-fighting foam	Red/Yellow	S 50 09 - S 50 12 - S 50 09

Pipe content identification

Pipe identification colour-coded tape according to ISO 14726: 2008 and NORSOK L-004



Steam	Colours	Item codes
Steam for heating purposes		S 50 08 - S 50 01 - S 50 08
Driving steam		S 50 08 - S 50 04 - S 50 08
Exhaust steam		S 50 08 - S 50 11 - S 50 08
Supply steam		S 50 08 - S 50 12 - S 50 08

Flammable gases	Colours	Item codes
Hydrogen		S 50 12 - S 50 02 - S 50 12
Acetylene		S 50 12 - S 50 05 - S 50 12
Liquid gas		S 50 12 - S 50 10 - S 50 12

Non-flammable gases	Colours	Item codes
Oxygen		S 50 05 - S 50 02 - S 50 05
Inert gas		S 50 05 - S 50 03 - S 50 05
Nitrogen		S 50 05 - S 50 04 - S 50 05
Refrigerant		S 50 05 - S 50 06 - S 50 05
Compressed air HP (High pressure)		S 50 05 - S 50 09 - S 50 05
Control air/regulating air		S 50 05 - S 50 10 - S 50 05
Breathing air*		S 50 05 - S 50 11 - S 50 05
Breathing gas*		S 50 05 - S 50 12 - S 50 05

* This marking is used in submarines for distribution systems of breathing air from cylinders.

Air and sounding pipes	Colours	Item codes
Waste media		S 50 06 - S 50 01 - S 50 06
Fresh water		S 50 06 - S 50 02 - S 50 06
Fuel		S 50 06 - S 50 03 - S 50 06
Sea water		S 50 06 - S 50 04 - S 50 06
Non-flammable gases		S 50 06 - S 50 05 - S 50 06
Oils other than fuels		S 50 06 - S 50 07 - S 50 06
Steam		S 50 06 - S 50 08 - S 50 06
Fire fighting		S 50 06 - S 50 09 - S 50 06
Acids, alkalis		S 50 06 - S 50 10 - S 50 06
Ventilation system		S 50 06 - S 50 11 - S 50 06
Flammable gases		S 50 06 - S 50 12 - S 50 06

Oils other than fuels	Colours	Item codes
Thermal fluid		S 50 07 - S 50 02 - S 50 07
Lubrication oil for gas turbines		S 50 07 - S 50 04 - S 50 07
Hydraulic fluid		S 50 07 - S 50 05 - S 50 07
Lubrication oil for steam turbines		S 50 07 - S 50 08 - S 50 07
Lubrication oil for gears		S 50 07 - S 50 10 - S 50 07
Lubrication oil for internal combustion engines		S 50 07 - S 50 12 - S 50 07

Non-flammable gases	Colours	Item codes
Oxygen		S 50 05 - S 50 02 - S 50 05
Inert gas		S 50 05 - S 50 03 - S 50 05
Nitrogen		S 50 05 - S 50 04 - S 50 05
Refrigerant		S 50 05 - S 50 06 - S 50 05
Compressed air LP (Low pressure)		S 50 05 - S 50 07 - S 50 05
Compressed air HP (High pressure)		S 50 05 - S 50 09 - S 50 05
Control air/regulating air		S 50 05 - S 50 10 - S 50 05
Breathing air*		S 50 05 - S 50 11 - S 50 05
Breathing gas*		S 50 05 - S 50 12 - S 50 05

* This marking is used in submarines for distribution systems of breathing air from cylinders.

Air in ventilation systems	Colours	Item codes
Discharge air		S 50 11 - S 50 01 - S 50 11
Mechanical supply air, cold		S 50 11 - S 50 02 - S 50 11
Natural exhaust air		S 50 11 - S 50 03 - S 50 11
Atmospheric air		S 50 11 - S 50 04 - S 50 11
Mechanical exhaust air		S 50 11 - S 50 05 - S 50 11
Decontaminated supply air		S 50 11 - S 50 06 - S 50 11
Mechanical recirculated air		S 50 11 - S 50 07 - S 50 11
Mechanical supply air, warm		S 50 11 - S 50 08 - S 50 11
Smoke clearance		S 50 11 - S 50 09 - S 50 11
Conditioned supply air		S 50 11 - S 50 10 - S 50 11
Natural supply air		S 50 11 - S 50 12 - S 50 11

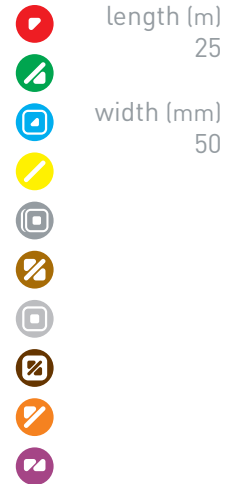

length (m)
25

width (mm)
50

Multiple colour rolls according to ISO 14726: 2008 and NORSOK L-004

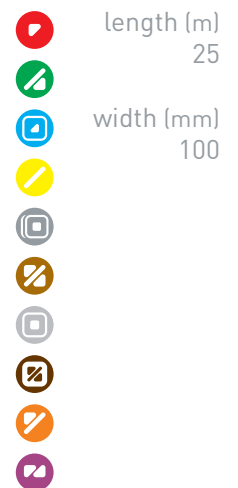

length (m)
25

width (mm)
100

Pipe content identification

Multiple colour rolls according to ISO 14726: 2008 and Norsok L-004

length (m)
25

width (mm)
100







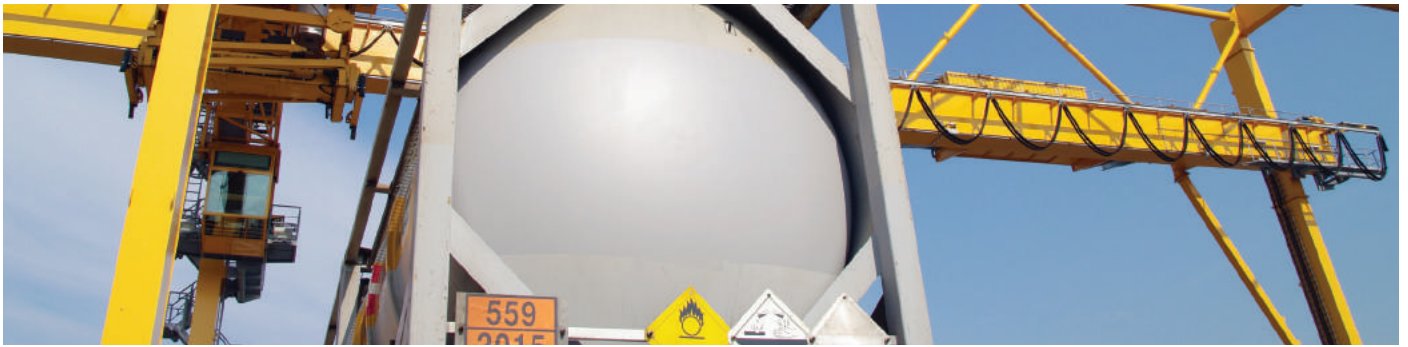



































S 52 18 Chilled water	S 52 19 Condensate	S 52 20 Non-flammable gases	S 52 21 Oxygen	S 52 22 Inert gas	S 52 23 Nitrogen
S 52 24 Refrigerant	S 52 25 Compressed air LP (low pressure)	S 52 26 Compressed air HP (high pressure)	S 52 27 Control air/regulating air	S 52 28 Breathing air	S 52 29 Breathing gas
S 52 30 Steam for heating processes	S 52 31 Driving steam	S 52 32 Exhaust steam	S 52 33 Supply steam	S 52 34 Waste media	S 52 35 Fresh water
S 52 36 Fuel	S 52 37 Sea water	S 52 38 Non-flammable gases	S 52 39 Oils other than fuels	S 52 40 Steam	S 52 41 Fire fighting
S 52 42 Acids, Alkalis	S 52 43 Ventilation system	S 52 44 Flammable gases	S 52 45 Oils other than fuels	S 52 46 Thermal fluid	S 52 47 Lubrication oil for gas turbines
S 52 48 Hydraulic fluid	S 52 49 Lubrication oil for steam turbines	S 52 50 Lubrication oil for gears	S 52 51 Lubrication oil for internal combustion engines	S 52 52 Heavy fuel oil (HFO)	S 52 53 Aviation fuel
S 52 54 Biological fuel	S 52 55 Gas-turbine fuel	S 52 56 Marine diesel oil (MDO)	S 52 57 Fire fighting water	S 52 58 Fire-fighting gas	S 52 59 Sprinkler water
S 52 60 Spray water	S 52 61 Fire-fighting powder	S 52 62 Fire-fighting foam	S 52 63 Discharge air	S 52 64 Mechanical supply air, cold	S 52 65 Natural exhaust air
S 52 66 Atmospheric air	S 52 67 Mechanical exhaust air	S 52 68 Decontaminated supply air	S 52 69 Mechanical recirculated air	S 52 70 Mechanical supply air, warm	S 52 71 Smoke clearance
S 52 72 Conditioned supply air	S 52 73 Natural supply air	S 52 74 Flammable gases	S 52 75 Hydrogen	S 52 76 Acetylene	S 52 77 Liquid gas

Signs according to the IMDG Code specifications





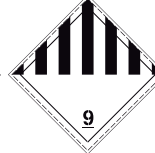









The International Maritime Dangerous Goods (IMDG) Code has been developed to create a uniform international code for the transport of dangerous goods by sea. The IMDG Code became mandatory in January 2004 through the adoption of the amendments to SOLAS chapter VII (Carriage of Dangerous Goods).

Hazard warning signs with classification numbers

							 100x100  200x200  250x250  300x300  400x400
S 55 01	S 55 02	S 55 03	S 55 04	S 55 05	S 55 06	S 55 07	
							
S 55 08	S 55 09	S 55 10	S 55 11	S 55 12	S 55 13	S 55 14	
							
S 55 15	S 55 16	S 55 17	S 55 18	S 55 19	S 55 20	S 55 21	
							
S 55 22	S 55 23	S 55 24	S 55 25	S 55 26	S 55 27	S 55 28	
							
S 55 29	S 55 30	S 55 31	S 55 32	S 55 33	S 55 34	S 55 35	

Hazard warning signs with UN numbers

							 100x100  200x200  250x250  300x300  400x400
S 56 01	S 56 02	S 56 03	S 56 04	S 56 05	S 56 06	S 56 07	

Signs according to the IMDG Code

Hazard warning signs with UN numbers

(mm)
100x100
200x200
250x250
300x300
400x400

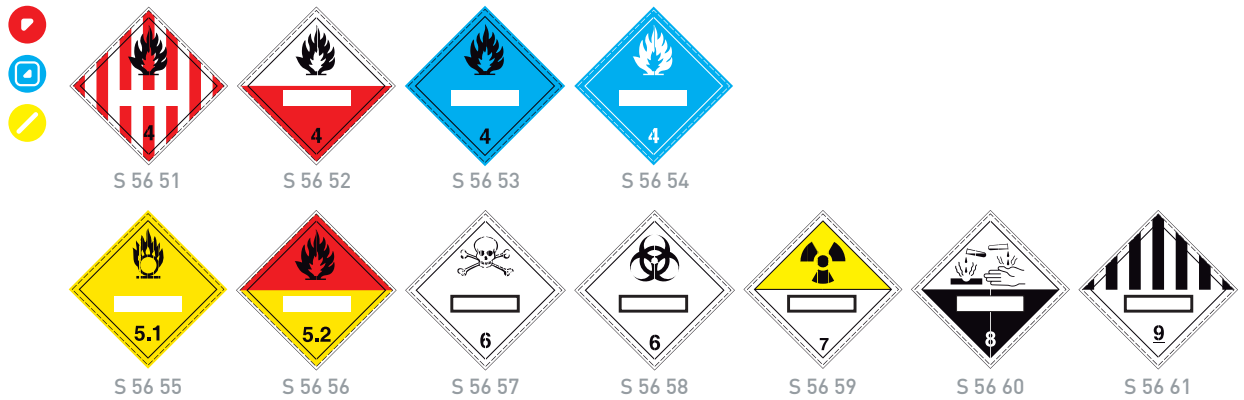

Marking signs for packages

(mm)
100x150
150x200



(mm)
100x100
250x250
300x300
base 300(*)

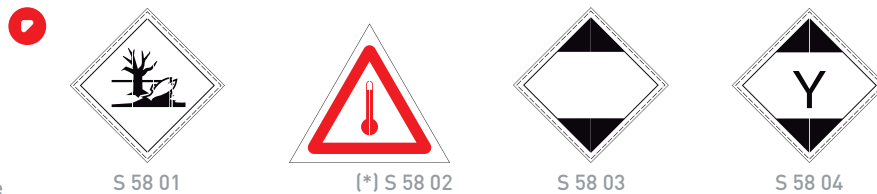

(*) Only available in this size

(mm)
100x100
250x250
300x250(*)

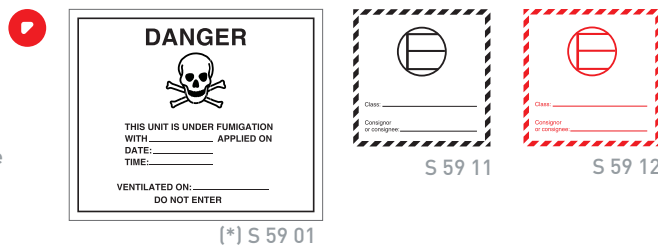

(*) Only available in this size

Safety signage according to Regulation (EC) No 1272/2008 on classification, labelling and packaging of substances and mixtures

(mm)
100x100
150x150
200x200
300x300



Info panels with sign symbols and meaning descriptions



The IMO International Safety Management (ISM) Code was developed with the aim of implementing safety practises at sea which would lead to the prevention of human injury or loss of life as well as the prevention of damage to the environment and property.

The  Everlux® safety procedures are in compliance with the ISM Code and provide you with the necessary training and information requirements that must be displayed on board.



S 60 01

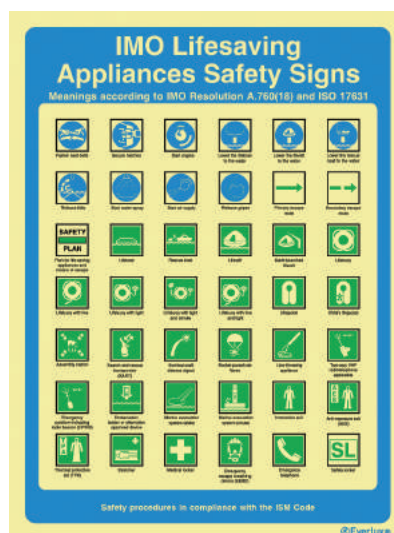

S 60 02

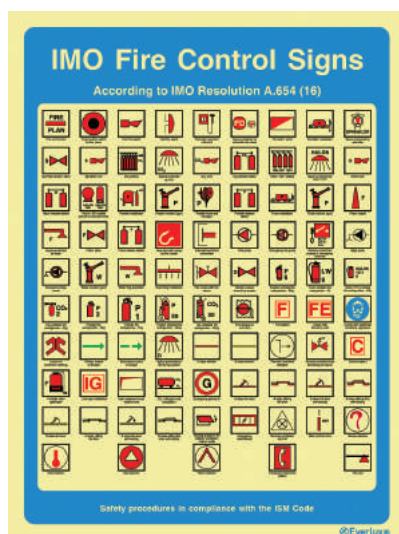
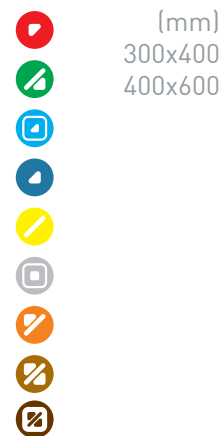

S 60 03

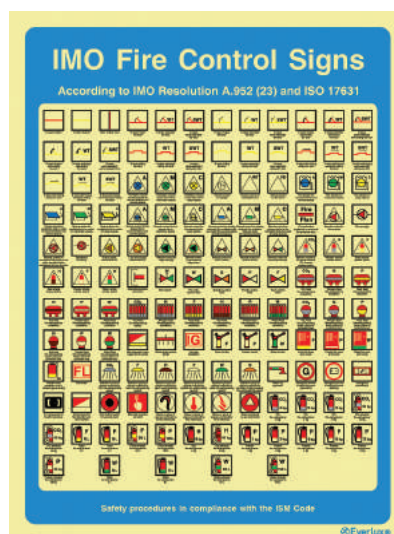

S 60 04

Safety awareness and training procedures

Info panels with sign symbols and meaning descriptions

(mm)
300x400
400x600



Pipe Identification

Identification colours for the content of piping systems
In accordance with ISO 14726: 2008

Content	Colour	Content	Colour
Water	Blue	Steam	Red
Oil	Yellow	Gas	Black
... (many more rows)

Safety procedures in compliance with the ISM Code

S 60 05

Hazardous Substance Pictograms

Globally Harmonized System of Classification and Labelling of Chemicals (GHS)
Labels/Labels (Globally Harmonized System symbols) and a list with G.P. Regulations

Symbol	Meaning	Precautions	Usage
	Explosive	... (text) (text) ...
	Flammable	... (text) (text) ...
	Corrosive	... (text) (text) ...
	Toxic	... (text) (text) ...
	Hazardous	... (text) (text) ...

Safety procedures in compliance with the ISM Code

S 60 09

Hazard Signs For the Transport of Dangerous Goods by Sea

Sign meanings according to the IMDG Code

Marking of Packages Containing Dangerous Goods

Safety procedures in compliance with the ISM Code

S 60 06

Know Your Signs

Meaning, colours and examples of graphics used for safety signs

- Safety signs meaning:**
 - Source of escape
 - First aid
 - Fire fighting
 - Prohibition
 - Prohibition
 - Prohibition
- Fire signs meaning:**
 - Location and type of fire fighting equipment
 - Fire extinguisher
 - Fire alarm
 - Fire escape
 - Fire exit
 - Fire exit
- Hazard and warning signs meaning:**
 - Nature of danger and/or reaction
 - Explosion
 - Flammable
 - Toxic
 - Corrosive
 - Radioactive
- Prohibition signs meaning:**
 - Stop
 - No smoking
 - No open flames
 - No mobile phones
 - No alcohol
 - No smoking
 - No mobile phones
 - No alcohol
- Mandatory signs meaning:**
 - They are required to carry out the action
 - Hand
 - Life jacket
 - Head protection
 - Personal fall protection

Safety procedures in compliance with the ISM Code

S 60 07

International Code of Signals Flag Signals

Letter	Flag	Meaning	Precedence
A	Blue	... (text) ...	1
B	Red	... (text) ...	2
C	White	... (text) ...	3
D	Blue	... (text) ...	4
E	Red	... (text) ...	5
F	White	... (text) ...	6
G	Blue	... (text) ...	7
H	Red	... (text) ...	8
I	White	... (text) ...	9
J	Blue	... (text) ...	0
K	Red	... (text) ...	
L	White	... (text) ...	
M	Blue	... (text) ...	

Safety procedures in compliance with the ISM Code

(*) S 60 08

(*) This panel is only available in white rigid plastic and white self-adhesive vinyl.

Evacuation and life-saving safety procedures

(mm)
300x400
400x600



Abandon Ship

Crucial actions preparing to abandon ship

- On hearing the emergency signal:
 - Put on your safety harness and life jacket.
 - Proceed to abandon ship station.
- Get survival craft ready:
 - Check survival craft status.
 - Collect life jackets, SART and survival kit.
- Boarding from deck:
 - DO NOT ABANDON SHIP UNTIL ORDERED TO DO SO.
 - Check your own survival kit.
 - Check your own survival kit.
 - Check your own survival kit.
- Boarding from water:
 - DO NOT LEAVE THE WATER UNLESS CRUCIALLY NECESSARY.
 - Check your own survival kit.
 - Check your own survival kit.
 - Check your own survival kit.

Safety procedures in compliance with the ISM Code

S 60 51

Man Overboard

Critical procedures on discovery of a man overboard

- Immediate actions from deck:
 - Throw lifebuoy to victim.
 - Alert bridge by normal means.
 - Alert shore by VHF.
 - Prepare for rescue.
- Immediate actions from bridge:
 - What has happened to victim?
 - Is victim in danger?
 - Is victim in danger?
 - Is victim in danger?
- Initial response within 30 seconds:
 - Position victim and bridge.
 - Post man overboard.
 - Learn only what is necessary.
 - Prepare for rescue and follow the bridge to rescue the victim.
- Initial response when at anchor or in harbor:
 - Use lifebuoy and life ring close to victim.
 - Prepare rescue plan and maintain contact with rescue boat.
 - Post man overboard.
 - Learn only what is necessary.
 - Prepare for rescue and follow the bridge to rescue the victim.
- Secondary response if victim not rescued:
 - Increase lookouts.
 - Search for victim.
 - Maintain log and keep reporting situation developments.

Safety procedures in compliance with the ISM Code

S 60 52

Evacuation and life-saving safety procedures

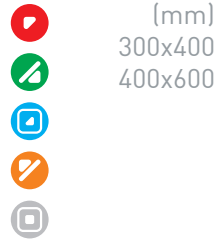

Liferaft Launching

Inflatable liferaft launching procedures

- Automatic Release**
 - Check that the liferaft is correctly stowed on the davit.
 - Check that the liferaft is correctly secured to the davit.
 - Check that the liferaft is correctly secured to the davit.
- Manual Release**
 - Locate the release handle, it is red.
 - Push the handle down to release the liferaft.
- Launch Liferaft**
 - Check that the liferaft is correctly stowed on the davit.
 - Check that the liferaft is correctly secured to the davit.
 - Check that the liferaft is correctly secured to the davit.
- Inflow Liferaft**
 - Check that the liferaft is correctly stowed on the davit.
 - Check that the liferaft is correctly secured to the davit.
 - Check that the liferaft is correctly secured to the davit.
- Automatic Release**
 - Check that the liferaft is correctly stowed on the davit.
 - Check that the liferaft is correctly secured to the davit.
 - Check that the liferaft is correctly secured to the davit.
- Rigging Upturned Liferaft**
 - Check that the liferaft is correctly stowed on the davit.
 - Check that the liferaft is correctly secured to the davit.
 - Check that the liferaft is correctly secured to the davit.

Safety procedures in compliance with the ISM Code

S 60 53

Davit Launched Liferafts

Instructions for davit launching inflatable liferafts

- Prepare the launch area**
 - Check that the launch area is clear of any obstructions.
 - Check that the launch area is clear of any obstructions.
 - Check that the launch area is clear of any obstructions.
- Prepare liferaft**
 - Check that the liferaft is correctly stowed on the davit.
 - Check that the liferaft is correctly secured to the davit.
 - Check that the liferaft is correctly secured to the davit.
- Inflatable procedure**
 - Check that the liferaft is correctly stowed on the davit.
 - Check that the liferaft is correctly secured to the davit.
 - Check that the liferaft is correctly secured to the davit.
- Lift off and fire out deck to power position**
 - Check that the liferaft is correctly stowed on the davit.
 - Check that the liferaft is correctly secured to the davit.
 - Check that the liferaft is correctly secured to the davit.
- Lower liferaft**
 - Check that the liferaft is correctly stowed on the davit.
 - Check that the liferaft is correctly secured to the davit.
 - Check that the liferaft is correctly secured to the davit.
- Release liferaft**
 - Check that the liferaft is correctly stowed on the davit.
 - Check that the liferaft is correctly secured to the davit.
 - Check that the liferaft is correctly secured to the davit.

Safety procedures in compliance with the ISM Code

S 60 54

Davit Launched Liferaft Procedures

Preparing for launching

- Check davit operation**
 - Check that the davit is correctly stowed on the ship.
 - Check that the davit is correctly secured to the ship.
 - Check that the davit is correctly secured to the ship.
- Check davit operation**
 - Check that the davit is correctly stowed on the ship.
 - Check that the davit is correctly secured to the ship.
 - Check that the davit is correctly secured to the ship.
- Lower to water**
 - Check that the liferaft is correctly stowed on the davit.
 - Check that the liferaft is correctly secured to the davit.
 - Check that the liferaft is correctly secured to the davit.
- Operate hook release for above water**
 - Check that the liferaft is correctly stowed on the davit.
 - Check that the liferaft is correctly secured to the davit.
 - Check that the liferaft is correctly secured to the davit.
- Check safety with vessel**
 - Check that the liferaft is correctly stowed on the davit.
 - Check that the liferaft is correctly secured to the davit.
 - Check that the liferaft is correctly secured to the davit.
- Fire up the hook for the next launch**
 - Check that the liferaft is correctly stowed on the davit.
 - Check that the liferaft is correctly secured to the davit.
 - Check that the liferaft is correctly secured to the davit.

Safety procedures in compliance with the ISM Code

S 60 73

Inflatable Liferafts

Essential procedures after launching

- Rigging upturned the raft**
 - Check that the liferaft is correctly stowed on the davit.
 - Check that the liferaft is correctly secured to the davit.
 - Check that the liferaft is correctly secured to the davit.
- Board quickly**
 - Check that the liferaft is correctly stowed on the davit.
 - Check that the liferaft is correctly secured to the davit.
 - Check that the liferaft is correctly secured to the davit.
- Move clear of the ship**
 - Check that the liferaft is correctly stowed on the davit.
 - Check that the liferaft is correctly secured to the davit.
 - Check that the liferaft is correctly secured to the davit.
- Stretch the sea anchor**
 - Check that the liferaft is correctly stowed on the davit.
 - Check that the liferaft is correctly secured to the davit.
 - Check that the liferaft is correctly secured to the davit.
- Close the entrance**
 - Check that the liferaft is correctly stowed on the davit.
 - Check that the liferaft is correctly secured to the davit.
 - Check that the liferaft is correctly secured to the davit.
- Further procedures**
 - Check that the liferaft is correctly stowed on the davit.
 - Check that the liferaft is correctly secured to the davit.
 - Check that the liferaft is correctly secured to the davit.

Safety procedures in compliance with the ISM Code

S 60 55

Lifeboat Launching

Launching open/deck-enclosed lifeboats safety procedures. Make sure that painter line is fitted.

- Initial preparations**
 - Check that the lifeboat is correctly stowed on the davit.
 - Check that the lifeboat is correctly secured to the davit.
 - Check that the lifeboat is correctly secured to the davit.
- Descend to deck level**
 - Check that the lifeboat is correctly stowed on the davit.
 - Check that the lifeboat is correctly secured to the davit.
 - Check that the lifeboat is correctly secured to the davit.
- Secure to embarkation deck**
 - Check that the lifeboat is correctly stowed on the davit.
 - Check that the lifeboat is correctly secured to the davit.
 - Check that the lifeboat is correctly secured to the davit.
- Board personnel**
 - Check that the lifeboat is correctly stowed on the davit.
 - Check that the lifeboat is correctly secured to the davit.
 - Check that the lifeboat is correctly secured to the davit.
- Descend to water**
 - Check that the lifeboat is correctly stowed on the davit.
 - Check that the lifeboat is correctly secured to the davit.
 - Check that the lifeboat is correctly secured to the davit.
- Letting go**
 - Check that the lifeboat is correctly stowed on the davit.
 - Check that the lifeboat is correctly secured to the davit.
 - Check that the lifeboat is correctly secured to the davit.

Safety procedures in compliance with the ISM Code

S 60 56

Hoisting Hook Directions For Launching Procedures

- Open slingshots in lashings**
 - Check that the slingshots are correctly stowed on the davit.
 - Check that the slingshots are correctly secured to the davit.
 - Check that the slingshots are correctly secured to the davit.
- Lift davit lever**
 - Check that the davit lever is correctly stowed on the davit.
 - Check that the davit lever is correctly secured to the davit.
 - Check that the davit lever is correctly secured to the davit.
- Embarkation**
 - Check that the lifeboat is correctly stowed on the davit.
 - Check that the lifeboat is correctly secured to the davit.
 - Check that the lifeboat is correctly secured to the davit.
- Lower liferaft**
 - Check that the liferaft is correctly stowed on the davit.
 - Check that the liferaft is correctly secured to the davit.
 - Check that the liferaft is correctly secured to the davit.
- Lowering**
 - Check that the liferaft is correctly stowed on the davit.
 - Check that the liferaft is correctly secured to the davit.
 - Check that the liferaft is correctly secured to the davit.

Safety procedures in compliance with the ISM Code

S 60 72

Safety awareness and training procedures

Evacuation and life-saving safety procedures

(mm)
300x400
400x600



Fully Enclosed Lifeboat Launching From Stowed Position

Procedures for launching (SOLAS consolidated 2004 edition (chapter II, regulation 23))

1 Initial measures

- Make sure launch warning plan are executed
- Evacuate according emergency plans
- Close all air-ops
- Close all fire doors
- Close all fire dampers
- Close all fire doors
- Close all fire doors

2 Launch action

- Release restraining device
- Release restraining device
- When in a safe situation, open valves
- When in a safe situation, open valves
- When in a safe situation, open valves

3 Lower to water

- Control the descent
- Control the descent
- Control the descent
- Control the descent

4 Ejecting water

- Make sure that water is ejected
- Make sure that water is ejected
- Make sure that water is ejected
- Make sure that water is ejected

5 Lifting up

- When in a dangerous atmosphere, open all safety and water
- When in a dangerous atmosphere, open all safety and water
- When in a dangerous atmosphere, open all safety and water

6 Final procedure

- Make sure that the lifeboat is in a safe position
- Make sure that the lifeboat is in a safe position
- Make sure that the lifeboat is in a safe position

Safety procedures in compliance with the ISM Code

S 60 57

Lifeboat Launching in a Dangerous Environment

Safety procedures

1 Confirm course to safe area

- Before leaving, take account bearing of all obstacles
- Before leaving, take account bearing of all obstacles
- Before leaving, take account bearing of all obstacles

2 How to proceed

- Go to the lifeboat launch area or the launch position
- Go to the lifeboat launch area or the launch position
- Go to the lifeboat launch area or the launch position

3 Begin air supply for passengers and engine

- Open air supply valves
- Open air supply valves
- Open air supply valves

4 Launch and start engine

- When the water valve is closed, the engine will start
- When the water valve is closed, the engine will start
- When the water valve is closed, the engine will start

5 Head for safety

- When the lifeboat is in a dangerous atmosphere, open all safety and water
- When the lifeboat is in a dangerous atmosphere, open all safety and water
- When the lifeboat is in a dangerous atmosphere, open all safety and water

6 Flarecast information

- Check that the information is received by the lifeboat
- Check that the information is received by the lifeboat
- Check that the information is received by the lifeboat

Safety procedures in compliance with the ISM Code

S 60 58

Partially and Fully Enclosed Lifeboats

Launching in clear atmosphere conditions

1 Release crew

- Turn on the lifeboat's engine
- Turn on the lifeboat's engine
- Turn on the lifeboat's engine

2 Check before launching

- Make sure the lifeboat is in a safe position
- Make sure the lifeboat is in a safe position
- Make sure the lifeboat is in a safe position

3 Helmet and harness

- Put on the helmet and harness
- Put on the helmet and harness
- Put on the helmet and harness

4 Ejector

- Release the ejector
- Release the ejector
- Release the ejector

5 Launching

- Release the lifeboat
- Release the lifeboat
- Release the lifeboat

6 Further actions

- Check the lifeboat's position
- Check the lifeboat's position
- Check the lifeboat's position

Safety procedures in compliance with the ISM Code

S 60 74

Free Fall Lifeboat Launching

Procedures

1 Release crew

- Turn on the lifeboat's engine
- Turn on the lifeboat's engine
- Turn on the lifeboat's engine

2 Check before launching

- Make sure the lifeboat is in a safe position
- Make sure the lifeboat is in a safe position
- Make sure the lifeboat is in a safe position

3 Helmet and harness

- Put on the helmet and harness
- Put on the helmet and harness
- Put on the helmet and harness

4 Ejector

- Release the ejector
- Release the ejector
- Release the ejector

5 Launching

- Release the lifeboat
- Release the lifeboat
- Release the lifeboat

6 Further actions

- Check the lifeboat's position
- Check the lifeboat's position
- Check the lifeboat's position

Safety procedures in compliance with the ISM Code

S 60 59

Evacuation Chutes & Slides

Safety procedures for abandoning ship with vertical chutes or angled slides

1 When you hear the emergency signal

- Prepare to use the chute or slide
- Prepare to use the chute or slide
- Prepare to use the chute or slide

2 Preparing to use the chute or slide

- Put on the life jacket
- Put on the life jacket
- Put on the life jacket

3 Using vertical chute

- Make sure the chute is in a safe position
- Make sure the chute is in a safe position
- Make sure the chute is in a safe position

4 After descending the chute

- When reaching the end of the chute, apply the brakes
- When reaching the end of the chute, apply the brakes
- When reaching the end of the chute, apply the brakes

5 Using angled slides

- Make sure the slide is in a safe position
- Make sure the slide is in a safe position
- Make sure the slide is in a safe position

6 After descending the slide

- When reaching the end of the slide, apply the brakes
- When reaching the end of the slide, apply the brakes
- When reaching the end of the slide, apply the brakes

Safety procedures in compliance with the ISM Code

S 60 60

Life Saving Signals

International search and rescue communication signals

1 Search and rescue signals

- Use the search and rescue signals
- Use the search and rescue signals
- Use the search and rescue signals

2 Search and rescue signals

- Use the search and rescue signals
- Use the search and rescue signals
- Use the search and rescue signals

3 Search and rescue signals

- Use the search and rescue signals
- Use the search and rescue signals
- Use the search and rescue signals

4 Search and rescue signals

- Use the search and rescue signals
- Use the search and rescue signals
- Use the search and rescue signals

Safety procedures in compliance with the ISM Code

S 60 61

Evacuation and life-saving safety procedures



(mm)
150x200
200x300

Item S 60 71 is a double sided panel

S 60 71

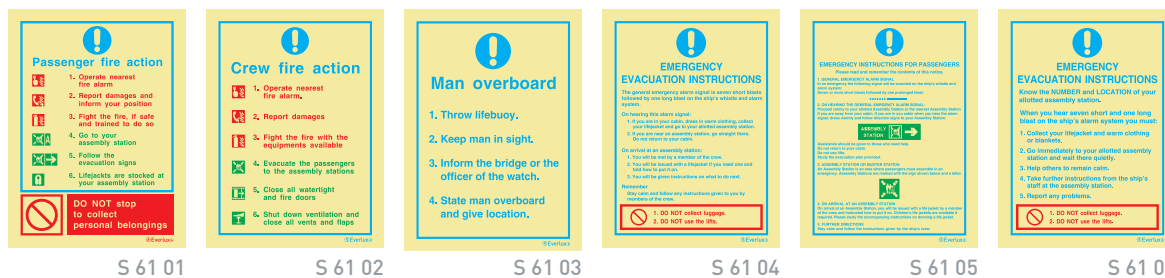

(mm)
150x200
200x300

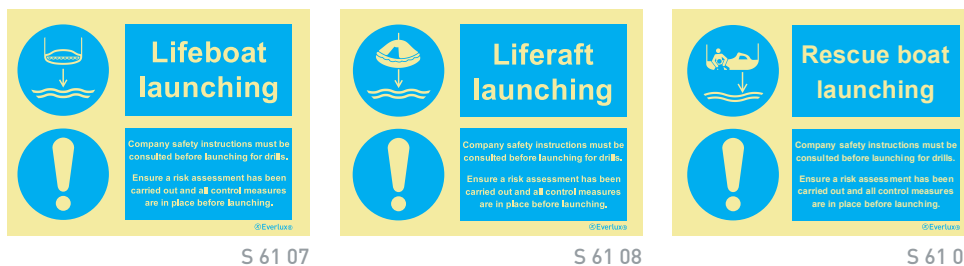

(mm)
200x150

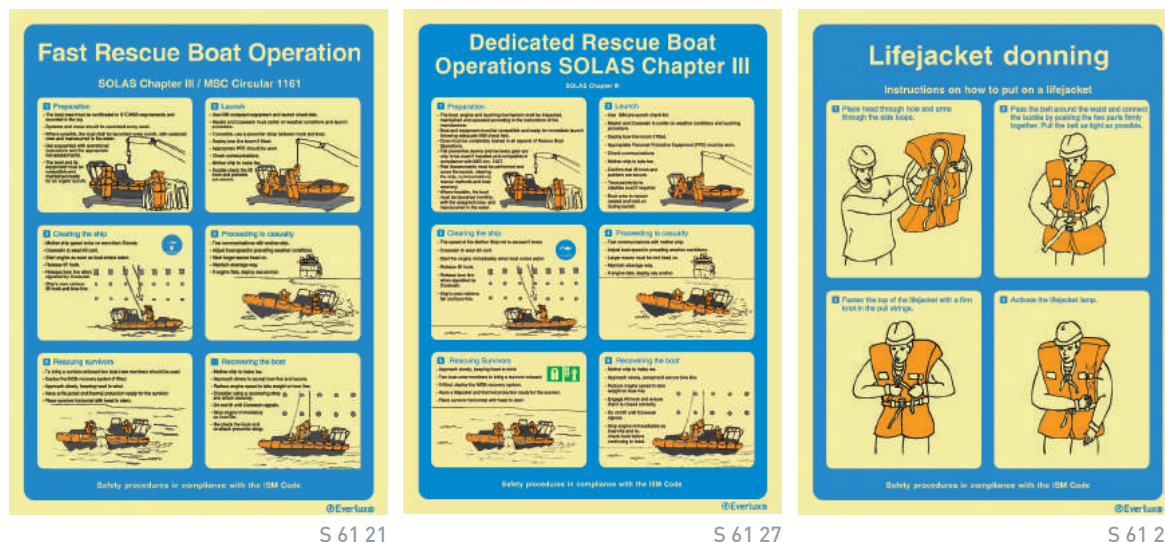

(mm)
300x400
400x600

Safety awareness and training procedures

Evacuation and life-saving safety procedures

(mm)
300x400
400x600



Immersion Suit Donning

Instructions on how to put on an immersion suit

1. Check the size and remove the suit
2. Slip in the suit with legs first
3. Pull the suit up and place left arm into sleeve of suit. Push the head of the suit over your head and slip your right arm into the sleeve
4. Pull the zipper down quickly and use the top cover and flap. Ensure that the zipper gap is between the 2 poles of the zipper
5. Put on flippers
6. Enter the water with feet first and head last, opening your flaps

Immersion suits are designed to be used in the event of an emergency. They are not intended for use in any other situation. They are not intended for use in any other situation. They are not intended for use in any other situation.

Safety procedures in compliance with the ISM Code

©Everluxa

S 61 23

Immersion, Survival or Anti-exposure Suits

ISOLAS TV Chapter 9/01.1, ISOLAS TV and MSC/Circ.1547

1. Donning
 - Remove suit from container or storage position.
 - Check all fastenings and ensure they are in good working order.
 - Check the suit for any damage or wear.
 - Place suit on the deck and ensure it is properly stored.
 - Check the suit for any damage or wear.
 - Check the suit for any damage or wear.
 - Check the suit for any damage or wear.
 - Check the suit for any damage or wear.
2. Entering water
 - Enter the water with feet first and head last.
 - Open the suit and ensure it is properly stored.
 - Check the suit for any damage or wear.
 - Check the suit for any damage or wear.
 - Check the suit for any damage or wear.
 - Check the suit for any damage or wear.
 - Check the suit for any damage or wear.
 - Check the suit for any damage or wear.
3. Ingressions and exits
 - Check the suit for any damage or wear.
 - Check the suit for any damage or wear.
 - Check the suit for any damage or wear.
 - Check the suit for any damage or wear.
 - Check the suit for any damage or wear.
 - Check the suit for any damage or wear.
 - Check the suit for any damage or wear.
 - Check the suit for any damage or wear.

Safety procedures in compliance with the ISM Code

©Everluxa

S 61 28

Helicopter Procedures

Winching

1. Preparation
 - Check the helicopter for any damage or wear.
 - Check the helicopter for any damage or wear.
 - Check the helicopter for any damage or wear.
 - Check the helicopter for any damage or wear.
 - Check the helicopter for any damage or wear.
 - Check the helicopter for any damage or wear.
 - Check the helicopter for any damage or wear.
 - Check the helicopter for any damage or wear.
2. Helicopter communication
 - Check the helicopter for any damage or wear.
 - Check the helicopter for any damage or wear.
 - Check the helicopter for any damage or wear.
 - Check the helicopter for any damage or wear.
 - Check the helicopter for any damage or wear.
 - Check the helicopter for any damage or wear.
 - Check the helicopter for any damage or wear.
 - Check the helicopter for any damage or wear.
3. Helicopter approach
 - Check the helicopter for any damage or wear.
 - Check the helicopter for any damage or wear.
 - Check the helicopter for any damage or wear.
 - Check the helicopter for any damage or wear.
 - Check the helicopter for any damage or wear.
 - Check the helicopter for any damage or wear.
 - Check the helicopter for any damage or wear.
 - Check the helicopter for any damage or wear.
4. Hoist Technique
 - Check the helicopter for any damage or wear.
 - Check the helicopter for any damage or wear.
 - Check the helicopter for any damage or wear.
 - Check the helicopter for any damage or wear.
 - Check the helicopter for any damage or wear.
 - Check the helicopter for any damage or wear.
 - Check the helicopter for any damage or wear.
 - Check the helicopter for any damage or wear.
5. Recovery
 - Check the helicopter for any damage or wear.
 - Check the helicopter for any damage or wear.
 - Check the helicopter for any damage or wear.
 - Check the helicopter for any damage or wear.
 - Check the helicopter for any damage or wear.
 - Check the helicopter for any damage or wear.
 - Check the helicopter for any damage or wear.
 - Check the helicopter for any damage or wear.

Safety procedures in compliance with the ISM Code

©Everluxa

S 61 24

Helicopter Operations Landing On

Refer to the appropriate flag code and International Maritime Signalbook code on the "Code to Helicopter Ship Operator" by the IS

1. Preparation
 - Check the helicopter for any damage or wear.
 - Check the helicopter for any damage or wear.
 - Check the helicopter for any damage or wear.
 - Check the helicopter for any damage or wear.
 - Check the helicopter for any damage or wear.
 - Check the helicopter for any damage or wear.
 - Check the helicopter for any damage or wear.
 - Check the helicopter for any damage or wear.
2. Helicopter communication
 - Check the helicopter for any damage or wear.
 - Check the helicopter for any damage or wear.
 - Check the helicopter for any damage or wear.
 - Check the helicopter for any damage or wear.
 - Check the helicopter for any damage or wear.
 - Check the helicopter for any damage or wear.
 - Check the helicopter for any damage or wear.
 - Check the helicopter for any damage or wear.
3. Landing
 - Check the helicopter for any damage or wear.
 - Check the helicopter for any damage or wear.
 - Check the helicopter for any damage or wear.
 - Check the helicopter for any damage or wear.
 - Check the helicopter for any damage or wear.
 - Check the helicopter for any damage or wear.
 - Check the helicopter for any damage or wear.
 - Check the helicopter for any damage or wear.
4. Helicopter approach
 - Check the helicopter for any damage or wear.
 - Check the helicopter for any damage or wear.
 - Check the helicopter for any damage or wear.
 - Check the helicopter for any damage or wear.
 - Check the helicopter for any damage or wear.
 - Check the helicopter for any damage or wear.
 - Check the helicopter for any damage or wear.
 - Check the helicopter for any damage or wear.
5. Helicopter recovery
 - Check the helicopter for any damage or wear.
 - Check the helicopter for any damage or wear.
 - Check the helicopter for any damage or wear.
 - Check the helicopter for any damage or wear.
 - Check the helicopter for any damage or wear.
 - Check the helicopter for any damage or wear.
 - Check the helicopter for any damage or wear.
 - Check the helicopter for any damage or wear.

Safety procedures in compliance with the ISM Code

©Everluxa

S 61 29

Helicopter Rescue Slings

Safety instructions

1. Rescue sling
 - Check the rescue sling for any damage or wear.
 - Check the rescue sling for any damage or wear.
 - Check the rescue sling for any damage or wear.
 - Check the rescue sling for any damage or wear.
 - Check the rescue sling for any damage or wear.
 - Check the rescue sling for any damage or wear.
 - Check the rescue sling for any damage or wear.
 - Check the rescue sling for any damage or wear.
2. Putting on the rescue sling
 - Check the rescue sling for any damage or wear.
 - Check the rescue sling for any damage or wear.
 - Check the rescue sling for any damage or wear.
 - Check the rescue sling for any damage or wear.
 - Check the rescue sling for any damage or wear.
 - Check the rescue sling for any damage or wear.
 - Check the rescue sling for any damage or wear.
 - Check the rescue sling for any damage or wear.
3. Rescue methods
 - Check the rescue sling for any damage or wear.
 - Check the rescue sling for any damage or wear.
 - Check the rescue sling for any damage or wear.
 - Check the rescue sling for any damage or wear.
 - Check the rescue sling for any damage or wear.
 - Check the rescue sling for any damage or wear.
 - Check the rescue sling for any damage or wear.
 - Check the rescue sling for any damage or wear.
4. Other rescue methods
 - Check the rescue sling for any damage or wear.
 - Check the rescue sling for any damage or wear.
 - Check the rescue sling for any damage or wear.
 - Check the rescue sling for any damage or wear.
 - Check the rescue sling for any damage or wear.
 - Check the rescue sling for any damage or wear.
 - Check the rescue sling for any damage or wear.
 - Check the rescue sling for any damage or wear.

Safety procedures in compliance with the ISM Code

©Everluxa

S 61 25

Descender Device

1. First person to descend
 - Check the descender device for any damage or wear.
 - Check the descender device for any damage or wear.
 - Check the descender device for any damage or wear.
 - Check the descender device for any damage or wear.
 - Check the descender device for any damage or wear.
 - Check the descender device for any damage or wear.
 - Check the descender device for any damage or wear.
 - Check the descender device for any damage or wear.
2. Descender arm
 - Check the descender device for any damage or wear.
 - Check the descender device for any damage or wear.
 - Check the descender device for any damage or wear.
 - Check the descender device for any damage or wear.
 - Check the descender device for any damage or wear.
 - Check the descender device for any damage or wear.
 - Check the descender device for any damage or wear.
 - Check the descender device for any damage or wear.
3. First rescuer
 - Check the descender device for any damage or wear.
 - Check the descender device for any damage or wear.
 - Check the descender device for any damage or wear.
 - Check the descender device for any damage or wear.
 - Check the descender device for any damage or wear.
 - Check the descender device for any damage or wear.
 - Check the descender device for any damage or wear.
 - Check the descender device for any damage or wear.
4. Next rescuer to descend
 - Check the descender device for any damage or wear.
 - Check the descender device for any damage or wear.
 - Check the descender device for any damage or wear.
 - Check the descender device for any damage or wear.
 - Check the descender device for any damage or wear.
 - Check the descender device for any damage or wear.
 - Check the descender device for any damage or wear.
 - Check the descender device for any damage or wear.
5. Last person to descend
 - Check the descender device for any damage or wear.
 - Check the descender device for any damage or wear.
 - Check the descender device for any damage or wear.
 - Check the descender device for any damage or wear.
 - Check the descender device for any damage or wear.
 - Check the descender device for any damage or wear.
 - Check the descender device for any damage or wear.
 - Check the descender device for any damage or wear.

Safety procedures in compliance with the ISM Code

©Everluxa

S 61 26

Navigation and harbour approach safety procedures

(mm)
400x300
600x400



Required Boarding Arrangements for Pilot

In accordance with SOLAS Regulation V/21 and IMO Recommendation A.1086(27)

1. RIGGING FOR FREEBOARDS OF 5 METRES OR LESS
2. COMBINATION ARRANGEMENT FOR SHIPS WITH A FREEBOARD OF MORE THAN 5 METRES
3. PILOT LADDER WINCH REEL

Safety procedures in compliance with the ISM Code

©Everluxa

S 62 00

Health and safety operational procedures

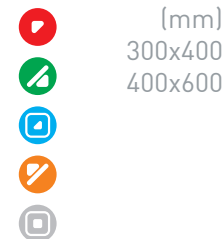

Hot Works

Recommended safety preparations for hot works

Hot work consists of any operation which generates sufficient heat to ignite flammable materials.

- Plan the work**
 - Consider the risks involved in the working conditions when planning the work. The tasks should be planned to prevent and avoid the fire risk. The fire protection plan must be approved before any hot work proceeds.
 - Fire emergency escape routes and assembly communication and emergency signals.
- Minimise the risks**
 - Consider the fire risks from the hot work. The hot work should be carried out in a safe area. The hot work should be carried out in a safe area. The hot work should be carried out in a safe area.
 - Make sure operations are properly supervised during and after the work.
 - Place safety signs and barriers around the work area. Remove any flammable materials from the work area.
- Prepare work area**
 - Clear work areas of all debris.
 - Remove any flammable materials from the work area.
 - Place safety signs and barriers around the work area.
 - Remove any flammable materials from the work area.
- Safety during and after work**
 - A hot work permit with suitable equipment and clear view of work must be carried. Check the fire risk before starting work.
 - Hot work should be carried out in a safe area.
 - Hot work should be carried out in a safe area.

Safety procedures in compliance with the ISM Code

S 63 03

Welding & Flamecutting

Safety procedures during welding operations

- General**
 - Welding operations should be carried out in a safe area.
 - Welding operations should be carried out in a safe area.
- Protective clothing**
 - Welding protective clothing should be worn at all times.
 - Welding protective clothing should be worn at all times.
- Precautions against fire & explosions**
 - Welding operations should be carried out in a safe area.
 - Welding operations should be carried out in a safe area.
- Electric welding equipment**
 - Welding operations should be carried out in a safe area.
 - Welding operations should be carried out in a safe area.
- Precautions during arc welding**
 - Welding operations should be carried out in a safe area.
 - Welding operations should be carried out in a safe area.
- Precautions during gas welding & cutting**
 - Welding operations should be carried out in a safe area.
 - Welding operations should be carried out in a safe area.

Safety procedures in compliance with the ISM Code

S 63 04

Personal Protective Equipment

Choosing the correct personal safety equipment

- Head protection**
 - Welding operations should be carried out in a safe area.
 - Welding operations should be carried out in a safe area.
- Eye protection**
 - Welding operations should be carried out in a safe area.
 - Welding operations should be carried out in a safe area.
- Ear protection**
 - Welding operations should be carried out in a safe area.
 - Welding operations should be carried out in a safe area.
- Hand protection**
 - Welding operations should be carried out in a safe area.
 - Welding operations should be carried out in a safe area.
- Foot protection**
 - Welding operations should be carried out in a safe area.
 - Welding operations should be carried out in a safe area.
- Specialised equipment**
 - Welding operations should be carried out in a safe area.
 - Welding operations should be carried out in a safe area.

Safety procedures in compliance with the ISM Code

S 63 05

Self Contained Breathing Apparatus

Safety measures of use in hazardous conditions

Where recharging facilities are not available, empty and low charged cylinders should be labelled and stored separately. Confirm that all cylinders are valid. Read and learn the manufacturer's instructions.

- Check weekly and before using**
 - Check the air supply and the air supply.
 - Check the air supply and the air supply.
- During the breathing operation**
 - Welding operations should be carried out in a safe area.
 - Welding operations should be carried out in a safe area.
- Requiring and verifying the functions**
 - Welding operations should be carried out in a safe area.
 - Welding operations should be carried out in a safe area.
- Getting ready to enter compartment**
 - Welding operations should be carried out in a safe area.
 - Welding operations should be carried out in a safe area.
- Initial operation**
 - Welding operations should be carried out in a safe area.
 - Welding operations should be carried out in a safe area.
- After operational use**
 - Welding operations should be carried out in a safe area.
 - Welding operations should be carried out in a safe area.

Safety procedures in compliance with the ISM Code

S 63 06

Enclosed Space Entry

Safety procedures for entering enclosed spaces

- Enclosed spaces are dangerous**
 - Welding operations should be carried out in a safe area.
 - Welding operations should be carried out in a safe area.
- Prepare space for entry**
 - Welding operations should be carried out in a safe area.
 - Welding operations should be carried out in a safe area.
- Prepare equipment**
 - Welding operations should be carried out in a safe area.
 - Welding operations should be carried out in a safe area.
- Prepare safety equipment**
 - Welding operations should be carried out in a safe area.
 - Welding operations should be carried out in a safe area.
- Communications and procedures**
 - Welding operations should be carried out in a safe area.
 - Welding operations should be carried out in a safe area.
- Avoid additional hazards**
 - Welding operations should be carried out in a safe area.
 - Welding operations should be carried out in a safe area.

Safety procedures in compliance with the ISM Code

S 63 07

Enclosed Space and Tank Rescue

Safety procedures for recovering a casualty from a dangerous atmosphere

- Raise the alarm**
 - Welding operations should be carried out in a safe area.
 - Welding operations should be carried out in a safe area.
- Commence rescue**
 - Welding operations should be carried out in a safe area.
 - Welding operations should be carried out in a safe area.
- Emergency first aid and rescue**
 - Welding operations should be carried out in a safe area.
 - Welding operations should be carried out in a safe area.
- First aid and other care**
 - Welding operations should be carried out in a safe area.
 - Welding operations should be carried out in a safe area.

Safety procedures in compliance with the ISM Code

S 63 08

Safety awareness and training procedures

Health and safety operational procedures

(mm)
300x400
400x600



Safety Signs for Enclosed Space Entry

Safety signs used to mark hazardous areas

Test the atmosphere of any space before entering. Some enclosed spaces on this vessel may contain a hazardous atmosphere that will not support life.

All instances of these spaces must be marked with the following signs. **NOT** to be decommissioned

	Danger Low oxygen level	Even a small decrease in the oxygen level can kill you at alarming speed without notice. Fluffy tanks and some cargoes absorb oxygen from the air.
	Danger Flammable atmosphere	The risk of explosion is of critical importance. Remember that even small pockets of gas displace the air you need. Suffocation and blackout is fast with no possibility of escape.
	No smoking or naked lights	
	Danger Toxic vapours	Some cargoes in all trades may release poisonous vapour into the air. You may not see or smell it. A druzain leaking followed by blackout and death is the likely conclusion.
	No access Authorized personnel only	One space can contain all these dangers.

Proper safety procedures for entering enclosed spaces must be carried out before allowing entrance. If it is difficult to get someone in difficulty, follow the ENCLOSED SPACE ENTRY SAFETY PROCEDURES.

Safety procedures in compliance with the ISM Code

©EverLux

S 63 09

Engine & Machinery Room Safety

Safe working procedures

General
Identify areas to be entered and avoid restricted hazards. Always wearing protective spaces, rubber-soled shoes, the fitting of a personal fall protection system, and a safety harness and fall arrest system. Do not work in a restricted space unless you are properly trained. Values must be safety tested. Do not work in a restricted space unless you are properly trained.

Electrical machinery spaces - LIME
Do not touch them. The effect of a discharge of electricity may damage the vessel. Always ensure that the power is off before working on any electrical equipment. Do not attempt to repair electrical equipment unless you are properly trained. Do not touch any electrical equipment unless you are properly trained.

Hot engines and cool surfaces
When starting machinery, be ready with moving parts and high temperatures. The temperature for starting hot oil and fuel beds, when they are at normal operating temperatures, is approximately 100°C. Do not touch any hot surfaces unless you are properly trained. Do not touch any hot surfaces unless you are properly trained.

Boilers
Maintenance working procedures are to be clearly displayed and observed. Do not touch any hot surfaces unless you are properly trained. Do not touch any hot surfaces unless you are properly trained.

Refrigeration machine
The danger of the rapidly expanding refrigerant of refrigeration machines is of critical importance. Remember that even small pockets of gas displace the air you need. Suffocation and blackout is fast with no possibility of escape.

Workshops and stores
There are at least three types of equipment that require special safety devices. Maintenance working procedures are to be clearly displayed and observed. Do not touch any hot surfaces unless you are properly trained. Do not touch any hot surfaces unless you are properly trained.

Safety procedures in compliance with the ISM Code

©EverLux

S 63 10

Craneage Safety

Craneage hand signals and safe working practices

STOP **WEST/LOOK SWEEP** **REVERSE/LIFT** **STOP** **EMERGENCY STOP** **OPERATIONS LEASE**

In the indicated direction

Signal with one hand and the other on head

Signal with both hands

Clutch and pushstart fingers to signal "ouch the motor" or "ouch the gear"

All bodies must have a common method for ISM. Operations must have had adequate training. Do not touch any hot surfaces unless you are properly trained. Do not touch any hot surfaces unless you are properly trained.

Safety procedures in compliance with the ISM Code

©EverLux

S 63 11

Working Aloft or Outboard

Be aware of the risks when working outboard and aloft

Preparation
Work on the vessel in the most secure position possible. Make sure equipment is safe. Use correct tie-off technique if applicable. Do not touch any hot surfaces unless you are properly trained. Do not touch any hot surfaces unless you are properly trained.

Risk awareness
4. Slip, trip and fall
5. Falls
6. Asphyxiation
7. Prolonged exposure
8. Exhaust gases
9. Slips, trips and falls
10. Asphyxiation
11. Prolonged exposure

Working aloft
Clear work area of obstructions and debris. Do not touch any hot surfaces unless you are properly trained. Do not touch any hot surfaces unless you are properly trained.

Use of portable equipment
When using a portable equipment, ensure that it is safe to use. Do not touch any hot surfaces unless you are properly trained. Do not touch any hot surfaces unless you are properly trained.

Working outboard
No outboard engine can be started up when outboard. Do not touch any hot surfaces unless you are properly trained. Do not touch any hot surfaces unless you are properly trained.

Safety procedures in compliance with the ISM Code

©EverLux

S 63 12

Bunkering

Safety procedures

Procedures before bunkering
Actions: Establish communication between ship and shore. Prepare fire fighting equipment. Check that fire and smoke detectors are working. Plug equipment. Plug the engine and the exhaust gas pipes. The oil flow is present and the filling. Check valves, valves and air connections.

Procedures during bunkering
Actions: Fully open oil/water separator. Increase loading rate before topping off. Check water when tank is topped. Check water separator when the tank is being filled. Check sufficient oil to the tank and flow.

Procedures after bunkering
Actions: Close and lock up machinery. Check off tank before filling it over the side. Check water separator when the tank is being filled. Check off any steps and clear signs. Check water separator when the tank is being filled.

Safety procedures in compliance with the ISM Code

©EverLux

S 63 13

Fire & Explosion

Crucial procedures

Sound the alarm
Alert the captain. Alert the crew. Alert the shore.

Immediate response
Close in emergency stations. Passengers should stay in their seats. Do not touch any hot surfaces unless you are properly trained. Do not touch any hot surfaces unless you are properly trained.

Limit the damage
Check off emergency and fire. Check off emergency and fire. Check off emergency and fire.

Containments
Send distress signal and location information. Do not touch any hot surfaces unless you are properly trained. Do not touch any hot surfaces unless you are properly trained.

Further actions if not
Alert the authorities. Communicate with the captain. Provide the party and signal. Establish communication with shore. Do not touch any hot surfaces unless you are properly trained. Do not touch any hot surfaces unless you are properly trained.

Safety procedures in compliance with the ISM Code

©EverLux

S 63 14

Health and safety operational procedures

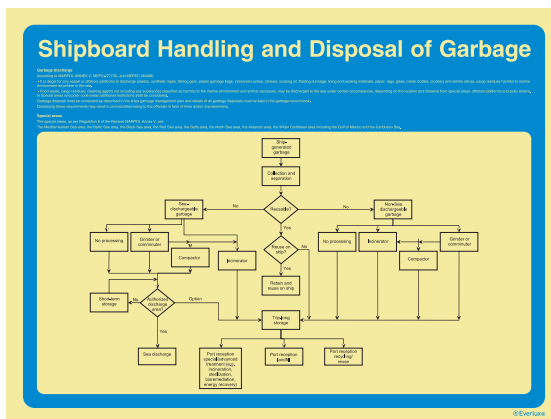
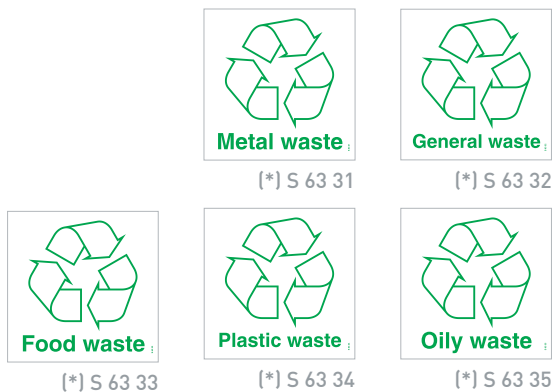

S 63 22

 (mm)
[*] 150x150
400x300
600x400

 (mm)
[*] Only available in this size



[*] S 63 72

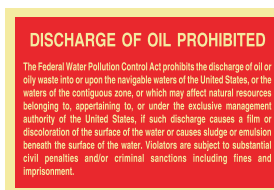

S 63 71

 (mm)
400x200
[*] 300x200

 (mm)
[*] Only available in this size

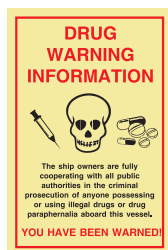

S 63 62



S 63 63



S 63 64

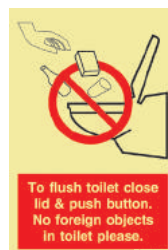

S 63 74

 (mm)
150x200
200x300

Safety awareness and training procedures - Spanish speaking crews

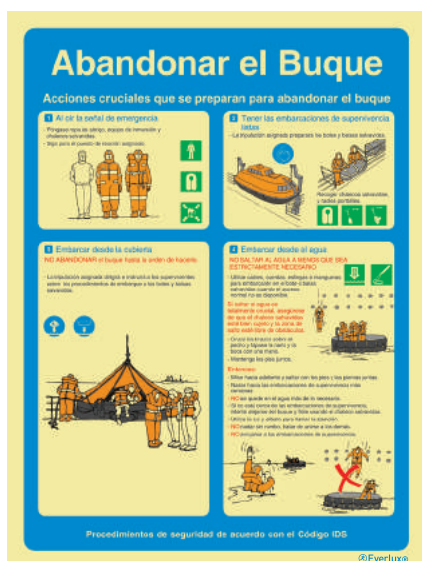





S 64 01



S 64 02

 (mm)
300x400
400x600

 (mm)
 (mm)
 (mm)
 (mm)

Safety awareness and training procedures

Safety awareness and training procedures - Spanish speaking crews

(mm)
300x400
400x600



Puesta a Flote del Bote Salvavidas

Procedimientos de seguridad para puesta a flote de los botes salvavidas abiertos/semi-cerrados. Asegurarse que la bota está lista.

Procedimientos de seguridad de acuerdo con el Código ISM

©Everlux

S 64 03

Puesta a Flote de un Bote Salvavidas Totalmente Cerrados

Procedimientos para el lanzamiento de un bote salvavidas totalmente cerrado

Procedimientos de seguridad de acuerdo con el Código ISM

©Everlux

S 64 04

Puesta a Flote de un Bote Salvavidas de Caída Libre

Consignas de seguridad para el lanzamiento de un bote salvavidas de caída libre

Procedimientos de seguridad de acuerdo con el Código ISM

©Everlux

S 64 05

Prevención de Derrames de Petróleo

Procedimientos para reducir la probabilidad de derrames de hidrocarburos

Procedimientos de seguridad de acuerdo con el Código ISM

©Everlux

S 64 06

Señalización de Seguridad Según la Resolución OMI A.760(18) e ISO 17631

Procedimientos de seguridad, en conformidad con el Código ISM

©Everlux

S 64 81

Señalización de Control de Incendios OMI

Simbología gráfica de control de incendios según la Resolución OMI A.654(16)

Procedimientos de seguridad, en conformidad con el Código ISM

©Everlux

S 64 82

Safety awareness and training procedures

Safety awareness and training procedures - French speaking crews

(mm)
 300x400
 400x600
 400x300(*)
 600x400(*)



Passerelles de Débarquement

Sécurisez le gréement et utilisez les passerelles

Procédures de sécurité en conformité avec le code ISM

©Everlux

S 64 73

Amarrage

Procédures de sécurité d'amarrage et de largage

Procédures de sécurité en conformité avec le code ISM

©Everlux

S 64 75

Remorquage

Procédures de sécurité recommandées pour les opérations de remorquage

ACTIONS de REMORQUAGE	ACTIONS du NAVIRE
1 A faire rapidement Vérifier que l'attelage est correctement installé et sécurisé. Vérifier que le remorqueur est correctement installé et sécurisé. Vérifier que le remorqueur est correctement installé et sécurisé. Vérifier que le remorqueur est correctement installé et sécurisé. Vérifier que le remorqueur est correctement installé et sécurisé.	1 A faire rapidement Vérifier que le remorqueur est correctement installé et sécurisé. Vérifier que le remorqueur est correctement installé et sécurisé. Vérifier que le remorqueur est correctement installé et sécurisé. Vérifier que le remorqueur est correctement installé et sécurisé. Vérifier que le remorqueur est correctement installé et sécurisé.
2 Remorquage au tirage Vérifier que le remorqueur est correctement installé et sécurisé. Vérifier que le remorqueur est correctement installé et sécurisé. Vérifier que le remorqueur est correctement installé et sécurisé. Vérifier que le remorqueur est correctement installé et sécurisé.	2 En remorque Vérifier que le remorqueur est correctement installé et sécurisé. Vérifier que le remorqueur est correctement installé et sécurisé. Vérifier que le remorqueur est correctement installé et sécurisé. Vérifier que le remorqueur est correctement installé et sécurisé.
3 Lâcher griffe Vérifier que le remorqueur est correctement installé et sécurisé. Vérifier que le remorqueur est correctement installé et sécurisé. Vérifier que le remorqueur est correctement installé et sécurisé. Vérifier que le remorqueur est correctement installé et sécurisé.	3 Lâcher griffe Vérifier que le remorqueur est correctement installé et sécurisé. Vérifier que le remorqueur est correctement installé et sécurisé. Vérifier que le remorqueur est correctement installé et sécurisé. Vérifier que le remorqueur est correctement installé et sécurisé.

Procédures de sécurité en conformité avec le code ISM

©Everlux

S 64 74

Dispositifs D'embarquement Requis pour le Pilote

©Everlux

(*) S 64 71

Prévention des Déversements D'hydrocarbures

Procédures pour réduire les risques de déversements d'hydrocarbures

Procédures de sécurité en conformité avec le code ISM

©Everlux

S 64 76

Soudage & Oxyacoupage

Procédures de sécurité lors des opérations de soudage

Procédures de sécurité en conformité avec le code ISM

©Everlux

S 64 77

Safety awareness and training procedures

Safety awareness and training procedures - Portuguese speaking crews

(mm)
300x400
400x600



Trabalho em Altura ou Fora de Bordo

Esteja ciente dos riscos ao trabalhar fora de bordo e em altura

1 Preparação
Antes de qualquer trabalho em altura ou fora de bordo, o pessoal deve ser devidamente treinado e autorizado para tal. O trabalho em altura ou fora de bordo deve ser planeado e autorizado pelo comandante da embarcação.

2 Identificação do risco
A equipe de risco deve ser avaliada antes de qualquer trabalho em altura ou fora de bordo. Os riscos devem ser identificados e avaliados antes de qualquer trabalho em altura ou fora de bordo.

3 Instruções
O pessoal deve ser devidamente treinado e autorizado para tal. O trabalho em altura ou fora de bordo deve ser planeado e autorizado pelo comandante da embarcação.

4 Trabalho em altura
O trabalho em altura deve ser realizado com o uso de equipamentos de segurança adequados. O pessoal deve ser devidamente treinado e autorizado para tal.

5 Uso de equipamentos pessoais
O pessoal deve usar equipamentos pessoais de segurança adequados. O trabalho em altura ou fora de bordo deve ser planeado e autorizado pelo comandante da embarcação.

6 Trabalhar fora de bordo
O trabalho fora de bordo deve ser realizado com o uso de equipamentos de segurança adequados. O pessoal deve ser devidamente treinado e autorizado para tal.

Procedimentos de segurança em conformidade com o Código ISM

©Everlux

S 64 50

Segurança com Garrafas de Gás

Manuseamento seguro, armazenamento e práticas operacionais

Cuidado extremo, atenção aos riscos

As garrafas de gás são dispositivos sob pressão e devem ser manuseadas com cuidado. O pessoal deve ser devidamente treinado e autorizado para tal. O trabalho com garrafas de gás deve ser planeado e autorizado pelo comandante da embarcação.

Procedimentos de segurança de manuseamento

Procedimentos de segurança de armazenamento

Procedimentos de segurança em conformidade com o Código ISM

©Everlux

S 64 51

Afogamento e Hipotermia

Ações a desenvolver ao descobrir uma vítima de afogamento ou hipotermia

1 Afogamento
O afogamento é a principal causa de morte por acidente de embarcação. O pessoal deve ser devidamente treinado e autorizado para tal. O trabalho de afogamento deve ser planeado e autorizado pelo comandante da embarcação.

2 Suporte Básico de Vida (SBV) (CoSTRA 2005)
O Suporte Básico de Vida (SBV) é um conjunto de procedimentos para a prestação de primeiros socorros a vítimas de afogamento ou hipotermia. O pessoal deve ser devidamente treinado e autorizado para tal.

3 Verificar a respiração

4 Verificar a circulação

5 Realizar a ressuscitação

6 Realizar a reanimação

7 Realizar o transporte

Procedimentos de segurança em conformidade com o Código ISM

©Everlux

S 64 52

Choques Elétricos e Lesões Graves

Durante as primeiras atividades de uma operação que não seja causada por ondas. A ventilação, assim como, é igualmente importante do que as compressões torácicas.

Choques elétricos

Lesões graves

Suporte Básico de Vida (SBV) (CoSTRA 2005)
O Suporte Básico de Vida (SBV) é um conjunto de procedimentos para a prestação de primeiros socorros a vítimas de afogamento ou hipotermia. O pessoal deve ser devidamente treinado e autorizado para tal.

1 Verificar a respiração

2 Verificar a circulação

3 Realizar a ressuscitação

4 Realizar a reanimação

5 Realizar o transporte

Procedimentos de segurança em conformidade com o Código ISM

©Everlux

S 64 60

Lançamento de balsa salvavidas

Procedimentos para o lançamento de balsas salva-vidas infláveis

1 Ativação automática

2 Ativação manual

3 Lançamento da balsa salvavidas

4 Realizar a balsa salvavidas

5 Ativação automática

6 Realizar a balsa salvavidas para cima

Procedimentos de segurança em conformidade com o Código ISM

©Everlux

S 64 53

(mm)
300x400
400x600



Balsas Salva-vidas Infláveis

Procedimentos essenciais após o lançamento à água

- 1. Inserir a balsa salva-vidas para cima**
- 2. Afundar do navio**
- 3. Fechar as amarras**
- 4. Emborcar rapidamente**
- 5. Lançar à água**
- 6. Manter a posição**

Procedimento de segurança em conformidade com o Código ISM

©Everlux

S 64 54

Lançamento da Baleeira em Condições Atmosféricas Perigosas

Procedimentos de segurança

- 1. Confirmação de tudo para uma segura deslocação a motor**
- 2. Início do abastecimento de ar para o motor**
- 3. Evacuar se para uma segura**
- 4. Certo preparar**
- 5. Lançamento a motor do sistema de ignição**
- 6. Informação relevante**

Procedimento de segurança de acordo ao código ISM

©Everlux

S 64 55

Higiene dos Alimentos a Bordo

Recomendações de saúde e segurança em copas, cozinhas e frigoríficos

- 1. Saúde e higiene**
- 2. Preparação dos alimentos**
- 3. Equipamentos de cozinha e limpeza**
- 4. Controle de temperatura**
- 5. Limpeza de equipamentos, utensílios e recipientes**
- 6. Manipulação segura de carne de aves e peixe**

Procedimento de segurança de acordo ao código ISM

©Everlux

S 64 56

Sinais de Salvamento

Sinais de comunicação internacional de busca e salvamento de acordo com os requerimentos SOLAS

Procedimento de segurança em conformidade com o Código ISM

©Everlux

S 64 57

Colocação do Colete Salva-vidas

Instruções para colocar o colete Salva-vidas

- 1. Colocar e colocar dentro da abertura superior e de braços nos aberturas laterais**
- 2. Deslizar o cinto e o peito do colete e conectar a fivela principal de duas partes com firmeza. Deve ser garantido que há uma fivela apertada posterior**
- 3. Apertar a parte superior do colete Salva-vidas com um dos cintos superiores**
- 4. Apertar a base do colete Salva-vidas**

Procedimento de segurança em conformidade com o Código ISM

©Everlux

S 64 58

Sinais de Luzes, Formatos e Sons

Sinais de comunicação internacional

Procedimento de segurança em conformidade com o Código ISM

©Everlux

S 64 59

General safety awareness notices

Safety awareness

(mm)
300x400
400x600



Safety First
Confined Spaces

Unless you know, avoid down below
Use the correct PPE & procedures!

©Everlux

S 65 01

Safety First
Electrical Safety

Be the only bright spark around
Think electrical safety!

©Everlux

S 65 02

Safety First
Eye Protection

To see or not to see, that is the question
Use eye protection!

©Everlux

S 65 03

Safety First
Fire Prevention

Play your part
Be fire smart!

©Everlux

S 65 04

Safety First
Follow Correct Procedures

Informed is better than deformed!

©Everlux

S 65 05

Safety First
Hazardous Materials

Safety is as simple as ABC
Always Be Careful and follow the instructions

©Everlux

S 65 06

Safety First
Housekeeping

Avoid a scene
Keep it clean!

©Everlux

S 65 07

Safety First
Lift Correctly

Keep safety on track
Look after your back!

©Everlux

S 65 08

Safety First
Noise

Hear today, gone tomorrow
Use hearing protection!

©Everlux

S 65 09

Safety First
Personal Protective Equipment (PPE)

No safety know pain, know safety no pain
Use the correct PPE!

©Everlux

S 65 10

Safety First
Seek Medical Attention

A wound neglected is a wound infected
Seek medical attention!

©Everlux

S 65 11

Safety First
Slips and Falls

A spill, a slip
A hospital trip!

©Everlux

S 65 12

The ©Everlux® general awareness safety notices can be used to remind the crew of the basic safety principles in order to create a safe environment on board.

When used together with the ©Everlux® safety awareness training procedures they will help you to comply with the ISM Code requirements

Deck safety plan

EMERGENCY INSTRUCTION NOTICE FOR PASSENGERS



ASSEMBLY STATIONS

YOU ARE HERE
USTED ESTÁ AQUÍ

<p>GENERAL EMERGENCY ALARM SIGNAL In the event of an Emergency the following signal will be sounded on the Ship's Whistle and on the Public Address System. We are not to be out on deck immediately.</p> <p>Signal (1) short blasts followed by one (1) long blast of the Ship's Whistle supplemented by the same signal over the Loudspeakers.</p> <p>ACTION ON HEARING THE GENERAL EMERGENCY SIGNAL On hearing the General Emergency Alarm Signal: 1. Proceed directly to your Assembly Station if you are in a location remote from your cabin. 2. If you are in your cabin or below deck you must remain in the cabin until you are ordered to leave. Do not use the lift or stairs. 3. Assist those who need help. 4. Follow the instructions of Crew Members and those given over the Public Address System. 5. DO NOT return to your cabin to collect your property. 6. DO NOT use lifts and 7. If the Primary Escape is blocked, use the Secondary Escape which is shown by a dotted arrow, as marked on the plan above.</p> <p>ASSEMBLY STATION An Assembly Station is a space where passengers assemble when the General Alarm Signal has been sounded. The Assembly Station of the ship are located on Deck 3.</p> <p>ACTIONS ON ARRIVAL AT THE ASSEMBLY STATION - Stay calm and follow the instructions of the Crew Members of your Assembly Station. - Put on your Lifejacket, if you do not have a Lifejacket Crew Members will obtain one for you.</p> <p>LOW LOCATION LIGHTING In the event of an Emergency, a Low Level (Secondary) System will be activated. It consists of a Lighted Strip placed on the floor outside your cabin. Follow the lighted strip to exit your cabin. If there is smoke in the corridor, keep close to the floor and crawl. If necessary, to avoid breathing the smoke, and to maintain visibility.</p> <p>IF YOU SEE SMOKE OR SMALL BURNING Inform the ship's personnel immediately.</p> <p>WATER OVERBOARD If you see someone fall overboard throw a Lifeline and inform immediately the ship's personnel.</p>	<p>SEÑAL DE EMERGENCIA GENERAL En caso de Emergencia la siguiente señal será producida por los Silbidos del Buque y por los Altavoces. No se debe salir del camarote inmediatamente.</p> <p>Señal (1) pulsos breves seguidos por uno (1) largo de la Señal de Silbido y repetidos por los Altavoces.</p> <p>ACCIONES DE REACTAR AL OÍR LA SEÑAL DE EMERGENCIA GENERAL Al oír la Señal de Emergencia General: 1. Si se encuentra en un lugar lejano de su camarote, diríjase directamente a la Estación de reunión correspondiente. 2. Si se encuentra en su camarote o en un lugar cubierto de su camarote, permanezca en su camarote hasta que se le indique lo contrario. No use ascensores, ni escaleras. 3. Ayude a quienes necesiten ayuda. 4. Siga las instrucciones de los Tripulantes y las indicaciones por los Altavoces. 5. NO regrese a su camarote a recoger sus pertenencias. 6. NO utilice ascensores y 7. Si la salida Principal se encuentra bloqueada, utilice la Salida Secundaria (mostrada con una línea punteada).</p> <p>ESTACIÓN DE REUNIÓN (ASSEMBLY STATION) Una Estación de Reunión es un punto en el cual los pasajeros se reúnen en caso de Emergencia. Las estaciones de reunión (Assembly Station) se encuentran en el Puente 3.</p> <p>ACCIONES DE REACTAR CUANDO LLEGUE A SU ESTACIÓN DE REUNIÓN - Permanezca tranquilo y siga las instrucciones de los Tripulantes en la Estación de Reunión. - Póngase su Chaleco Salvavidas. Si no tiene Chaleco Salvavidas, pídale a un Miembro de la Tripulación.</p> <p>SEÑAL LUMINOSA En caso de Emergencia, se activará un sistema luminoso. Este sistema consiste en una cinta luminosa colocada en una cinta luminosa fuera de su camarote. Siga el camino luminoso hasta llegar a su salida. En caso de humo en los pasillos, manténgase bajo y, si es necesario, no más cerca posible del suelo, para evitar ser inhalado el humo y para tener mejor visibilidad.</p> <p>EN CASO DE VER SMOKE O OLOR DE QUEMADO Informe al personal inmediatamente.</p> <p>AGÜAS FUERA A BORDO Si usted ve caer una persona en el agua, lance inmediatamente un salvavidas y avise al personal del barco.</p>
---	---

©Everlux®

(mm)
300x400
400x600
600x900



S DEC P

Cabin safety plan

EMERGENCY INSTRUCTION NOTICE FOR PASSENGERS

YOUR ASSEMBLY STATION IS
SU ESTACIÓN DE REUNIÓN SE HALLA EN

DECK 3
PUENTE 3

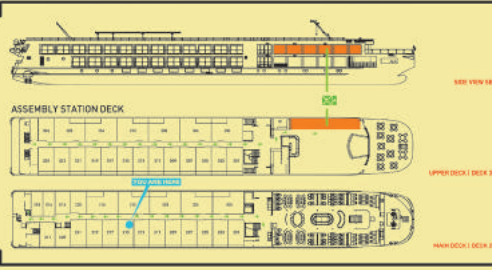

PRIMARY ESCAPE
Salida Principal

YOUR CABIN
SU CABINA

SECONDARY ESCAPE
Salida Secundaria

<p>GENERAL EMERGENCY ALARM SIGNAL In the event of an Emergency the following signal will be sounded on the Ship's Whistle and on the Public Address System. We are not to be out on deck immediately.</p> <p>Signal (1) short blasts followed by one (1) long blast of the Ship's Whistle supplemented by the same signal over the Loudspeakers.</p> <p>ACTION ON HEARING THE GENERAL EMERGENCY SIGNAL On hearing the General Emergency Alarm Signal: 1. Proceed directly to your Assembly Station if you are in a location remote from your cabin. 2. If you are in your cabin or below deck you must remain in the cabin until you are ordered to leave. Do not use the lift or stairs. 3. Assist those who need help. 4. Follow the instructions of Crew Members and those given over the Public Address System. 5. DO NOT return to your cabin to collect your property. 6. DO NOT use lifts and 7. If the Primary Escape is blocked, use the Secondary Escape which is shown by a dotted arrow, as marked on the plan above.</p> <p>ASSEMBLY STATION An Assembly Station is a space where passengers assemble when the General Alarm Signal has been sounded. The Assembly Station of the ship are located on Deck 3.</p> <p>ACTIONS ON ARRIVAL AT THE ASSEMBLY STATION - Stay calm and follow the instructions of the Crew Members of your Assembly Station. - Put on your Lifejacket, if you do not have a Lifejacket Crew Members will obtain one for you.</p> <p>LOW LOCATION LIGHTING In the event of an Emergency, a Low Level (Secondary) System will be activated. It consists of a Lighted Strip placed on the floor outside your cabin. Follow the lighted strip to exit your cabin. If there is smoke in the corridor, keep close to the floor and crawl. If necessary, to avoid breathing the smoke, and to maintain visibility.</p> <p>IF YOU SEE SMOKE OR SMALL BURNING Inform the ship's personnel immediately.</p> <p>WATER OVERBOARD If you see someone fall overboard throw a Lifeline and inform immediately the ship's personnel.</p>	<p>SEÑAL DE EMERGENCIA GENERAL En caso de Emergencia la siguiente señal será producida por los Silbidos del Buque y por los Altavoces. No se debe salir del camarote inmediatamente.</p> <p>Señal (1) pulsos breves seguidos por uno (1) largo de la Señal de Silbido y repetidos por los Altavoces.</p> <p>ACCIONES DE REACTAR AL OÍR LA SEÑAL DE EMERGENCIA GENERAL Al oír la Señal de Emergencia General: 1. Si se encuentra en un lugar lejano de su camarote, diríjase directamente a la Estación de reunión correspondiente. 2. Si se encuentra en su camarote o en un lugar cubierto de su camarote, permanezca en su camarote hasta que se le indique lo contrario. No use ascensores, ni escaleras. 3. Ayude a quienes necesiten ayuda. 4. Siga las instrucciones de los Tripulantes y las indicaciones por los Altavoces. 5. NO regrese a su camarote a recoger sus pertenencias. 6. NO utilice ascensores y 7. Si la salida Principal se encuentra bloqueada, utilice la Salida Secundaria (mostrada con una línea punteada).</p> <p>ESTACIÓN DE REUNIÓN (ASSEMBLY STATION) Una Estación de Reunión es un punto en el cual los pasajeros se reúnen en caso de Emergencia. Las estaciones de reunión (Assembly Station) se encuentran en el Puente 3.</p> <p>ACCIONES DE REACTAR CUANDO LLEGUE A SU ESTACIÓN DE REUNIÓN - Permanezca tranquilo y siga las instrucciones de los Tripulantes en la Estación de Reunión. - Póngase su Chaleco Salvavidas. Si no tiene Chaleco Salvavidas, pídale a un Miembro de la Tripulación.</p> <p>SEÑAL LUMINOSA En caso de Emergencia, se activará un sistema luminoso. Este sistema consiste en una cinta luminosa colocada en una cinta luminosa fuera de su camarote. Siga el camino luminoso hasta llegar a su salida. En caso de humo en los pasillos, manténgase bajo y, si es necesario, no más cerca posible del suelo, para evitar ser inhalado el humo y para tener mejor visibilidad.</p> <p>EN CASO DE VER SMOKE O OLOR DE QUEMADO Informe al personal inmediatamente.</p> <p>AGÜAS FUERA A BORDO Si usted ve caer una persona en el agua, lance inmediatamente un salvavidas y avise al personal del barco.</p>
---	---

©Everlux®

(mm)
200x300



S CAB P



Fire control and safety plans

⊗ Everlux® self-adhesive mini-symbols

The ⊗ Everlux® self-adhesive mini-symbols are the ideal solution to update the locations of fire fighting and life-saving equipments in the fire control and safety plans.

The mini-symbols follow the IMO and ISO regulations and are available in 4 packs. Ref. S 70 01, S 70 02 and S 70 03 according to each relevant regulation/ standard as described below. The fourth pack consists of these 3 sets together. It contains 36 pages and a total of 4338 mini-symbols. It can be purchased by ordering Ref. S 70 00.

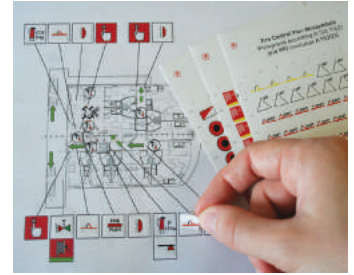

(mm)
10x10(*)

(*) Each
mini-symbol

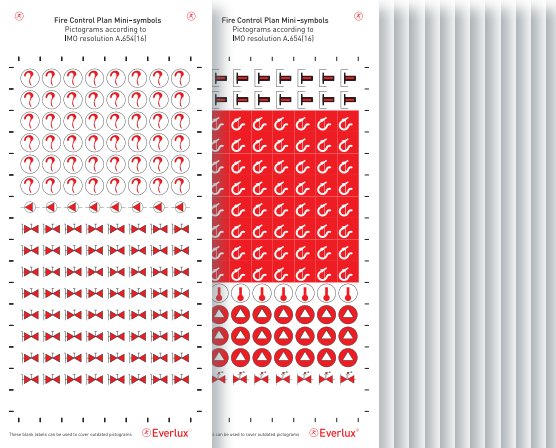

S 70 01

Fire control mini-symbols according to IMO Resolution A. 654 - containing 12 pages and a total of 1536 mini-symbols.

(mm)
10x10(*)

(*) Each
mini-symbol

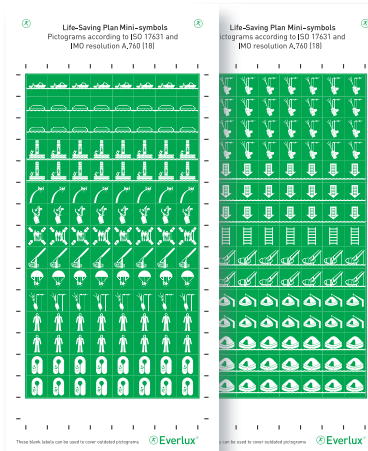

S 70 02

Life-saving mini-symbols according to ISO 17631 and IMO Resolution A. 760 - containing 6 pages and a total of 768 mini-symbols.

(mm)
10x10(*)

(*) Each
mini-symbol

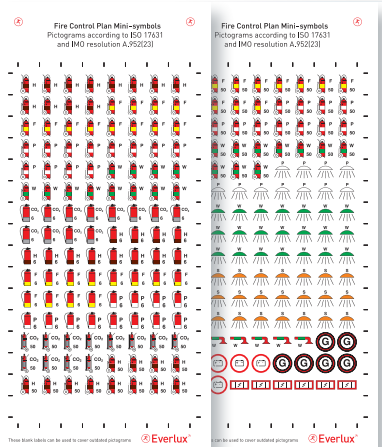

S 70 03

Fire control mini-symbols according to ISO 17631 and IMO Resolution A. 952 - containing 18 pages and a total of 2034 mini-symbols.

Decorative and onboard way-finding signs

ⓈEverlux® has the ability to design, develop and manufacture way-finding and decorative signage solutions in different base materials, always with a high concern on the aesthetics of the signs and their most suitable integration with the general interior decoration of the vessel.

Cabin identification



Deck identification and cabin facility way-finding



For more information on this service, please contact us at: commercial@everluxmaritime.com

□ Frame and Adhesive

⊗ Everlux® frames



Self-Assembly Frame S 80 01



Slim-Line Frame S 80 02

⊗ Everlux® frames are the ideal accessory when installing safety signs providing an aesthetic finish. They have a discreet and elegant design and are manufactured using high quality materials. They allow the connection between the sign and the wall and their visual weight does not conflict with the sign, resulting in a perfect harmony between the three elements (wall-frame-sign).

Properties:
Material: Aluminium

Available models:
⊗ Everlux® self-assembly frame – 4 aluminium components, cut to match the size of the sign are supplied along with 4 plastic “L” connectors and 4 squares of double-sided adhesive tape, to allow putting together this practical frame.

⊗ Everlux® slim-line frame – supplied with the respective sign and ready to be installed.

Installation:
Both frames can be pasted to the wall by using double-sided adhesive tape or ⊗ Everlux® adhesive. Frames are only suitable to square and rectangular shaped signs.

⊗ Everlux® adhesive



Applied correctly
⊗ Everlux® adhesive
has been proven to be
more cost effective
than other adhesive
brands

Adhesive (290ml) ADHE

Clean and fast application, is flexible with excellent mechanical properties indoor and outdoor. Free of solvents and silicone.

High adhesion to most surfaces, including irregular surfaces. Resistant to temperature variations and UV rays.

Signs and application surfaces must be clean and degreased. application must be done within + 5°C to + 40°C.

Apply a 5mm N-shaped adhesive wire on the back of the plate to cover the entire area. Press the sign against the installation surface. You can adjust the sign position within the first 5 minutes after the installation.

The service temperature is -40°C to + 90°C.

With a cord of 5mm in diameter and 15m linear: 29 signs (15x15cm), 19 signs (30x15cm), 12 signs (40x30 cm).

Apply the product in well ventilated areas. Contains: Bis(1,2,2,6,6-pentamethyl-4-piperidyl)sebacate, N-(3-(trimethoxysilyl) propyl)ethylenediamine. May cause allergic reaction. In case of contact with eyes, rinse with plenty of water.

Use a cloth moistened with alcohol to clean the surface of the sign and the installation surface. Store in a cool and dry place, with temperatures between + 5°C and +25°C.



IMPA and ISSA cross reference guide

IMPA	ISSA	Everlux	Page	IMPA	ISSA	Everlux	Page	IMPA	ISSA	Everlux	Page	IMPA	ISSA	Everlux	Page
33.1501	47.515.01	S 60 56	73	33.1547	47.515.47	S 63 06	79	33.2218	47.522.18	S 55 30	69	33.2292	47.522.92	S 57 12	70
33.1502	47.515.02	S 60 53	73	33.1548	47.515.48	S 60 06	72	33.2219	47.522.19	S 55 31	69	33.2293	47.522.93	S 58 02	70
33.1503	47.515.03	S 60 55	73	33.1557	47.515.57	S 60 03	71	33.2220	47.522.20	S 55 33	69	33.2294	47.522.94	S 55 15	69
33.1504	47.515.04	S 60 57	74	33.1558	47.515.58	S 60 61	74	33.2221	47.522.21	S 55 34	69	33.2295	47.522.95	S 55 17	69
33.1505	47.515.05	S 60 58	74	33.1559	47.515.59	S 60 71	75	33.2222	47.522.22	S 55 02	69	33.2296	47.522.96	S 55 20	69
33.1506	47.515.06	S 63 07	79	33.1564	47.515.64	S 62 06	77	33.2223	47.522.23	S 55 03	69	33.2297	47.522.97	S 55 24	69
33.1507	47.515.07	S 63 09	80	33.1565	47.515.65	S 62 53	78	33.2224	47.522.24	S 55 04	69	33.2298	47.522.98	S 55 33	69
33.1508	47.515.08	S 63 01	78	33.1566	47.515.66	S 60 05	72	33.2225	47.522.25	S 55 05	69	33.2300	47.523.00	S5715	70
33.1509	47.515.09	S 63 18	81	33.1568	47.515.68	S 60 07	72	33.2226	47.522.26	S 55 06	69	33.2760	47.527.60	S3292	42
33.1510	47.515.10	S 62 52	78	33.1569	47.515.69	S 63 17	81	33.2227	47.522.27	S 55 07	69	33.2761	47.527.61	S 32 93	42
33.1511	47.515.11	S 62 51	78	33.1570	47.515.70	S6316	81	33.2228	47.522.28	S 55 08	69	33.2762	47.527.62	S 32 94	42
33.1512	47.515.12	S 62 54	78	33.1571	47.515.71	S 62 07	77	33.2229	47.522.29	S 55 09	69	33.2763	47.527.63	S 32 91	42
33.1513	47.515.13	S 62 03	77	33.1573	47.515.73	S 61 21	75	33.2230	47.522.30	S 56 61	70	33.3141	47.531.41	S 41 07	53
33.1514	47.515.14	S 62 04	77	33.1579	47.515.79	S 60 08	72	33.2231	47.522.31	S 56 01	69	33.2401	47.524.01	S 42 51	54
33.1515	47.515.15	S 60 52	72	33.2086	47.520.86	S 21 80	36	33.2232	47.522.32	S 56 06	69	33.2402	47.524.02	S 42 52	54
33.1516	47.515.16	S 60 51	72	33.2130	47.521.30	S 50 00	66	33.2233	47.522.33	S 56 03	69	33.2403	47.524.03	S 42 53	54
33.1517	47.515.17	S 63 08	79	33.2140	47.521.40	S 50 01	66	33.2234	47.522.34	S 56 05	69	33.2404	47.524.04	S 42 54	54
33.1520	47.515.20	S 60 59	74	33.2141	47.521.41	S 50 02	66	33.2235	47.522.35	S 56 51	70	33.2405	47.524.05	S 42 55	54
33.1521	47.515.21	S 62 05	77	33.2142	47.521.42	S 50 03	66	33.2236	47.522.36	S 56 52	70	33.2406	47.524.06	S 42 56	54
33.1522	47.515.22	S 63 13	80	33.2143	47.521.43	S 50 04	66	33.2237	47.522.37	S 56 53	70	33.2407	47.524.07	S 42 57	54
33.1523	47.515.23	S 63 02	78	33.2144	47.521.44	S 50 05	66	33.2238	47.522.38	S 56 55	70	33.2408	47.524.08	S 42 58	54
33.1524	47.515.24	S 63 03	79	33.2145	47.521.45	S 50 06	66	33.2277	47.522.77	S 56 56	70	33.2409	47.524.09	S 42 59	54
33.1525	47.515.25	S 63 12	80	33.2146	47.521.46	S 50 07	66	33.2240	47.522.40	S 56 57	70	33.2410	47.524.10	S 42 60	54
33.1526	47.515.26	S 62 00	76	33.2147	47.521.47	S 50 08	66	33.2241	47.522.41	S 56 58	70	33.2411	47.524.11	S 42 61	54
33.1527	47.515.27	S 60 01	71	33.2148	47.521.48	S 50 09	66	33.2242	47.522.42	S 56 59	70	33.2412	47.524.12	S 42 62	54
33.1528	47.515.28	S 63 05	79	33.2149	47.521.49	S 50 10	66	33.2243	47.522.43	S 56 60	70	33.2413	47.524.13	S 42 01	54
33.1529	47.515.29	S 63 22	83	33.2150	47.521.50	S 50 11	66	33.2244	47.522.44	S 56 60	70	33.2414	47.524.14	S 42 63	54
33.1530	47.515.30	S 63 11	80	33.2151	47.521.51	S 50 12	66	33.2248	47.522.48	S 55 10	69	33.2415	47.524.15	S 42 64	54
33.1531	47.515.31	S 63 14	80	33.2201	47.522.01	S 59 01	70	33.2249	47.522.49	S 55 11	69	33.2416	47.524.16	S 42 65	54
33.1532	47.515.32	S 63 15	81	33.2202	47.522.02	S 55 19	69	33.2251	47.522.51	S 55 12	69	33.2417	47.524.17	S 42 66	54
33.1533	47.515.33	S 63 04	79	33.2203	47.522.03	S 55 01	69	33.2252	47.522.52	S 55 13	69	33.2418	47.524.18	S 42 67	54
33.1534	47.515.34	S 62 02	77	33.2207	47.522.07	S 55 14	69	33.2253	47.522.53	S 55 32	69	33.2419	47.524.19	S 42 04	54
33.1535	47.515.35	S6310	80	33.2208	47.522.08	S 55 16	69	33.2254	47.522.54	S 56 02	69	33.2420	47.524.20	S 42 02	54
33.1536	47.515.36	S 60 02	71	33.2209	47.522.09	S 55 18	69	33.2255	47.522.55	S 56 04	69	33.2421	47.524.21	S 42 03	54
33.1537	47.515.37	S 63 62	83	33.2210	47.522.10	S 55 21	69	33.2256	47.522.56	S 56 07	69	33.2422	47.524.22	S 42 68	54
33.1539	47.515.39	S 63 64	83	33.2211	47.522.11	S 55 22	69	33.2275	47.522.75	S 55 26	69	33.2423	47.524.23	S 42 69	54
33.1541	47.515.41	S 63 63	83	33.2212	47.522.12	S 55 23	69	33.2277	47.522.77	S 56 56	70	33.2424	47.524.24	S 42 70	54
33.1542	47.515.42	S 63 21	82	33.2213	47.522.13	S 55 25	69	33.2279	47.522.79	S 58 01	70	33.2425	47.524.25	S 42 71	54
33.1543	47.515.43	S 63 71	83	33.2275	47.522.75	S 55 26	69	33.2287	47.522.87	S 59 27	70	33.2426	47.524.26	S 42 72	54
33.1544	47.515.44	S 6319	81	33.2215	47.522.15	S 55 27	69	33.2288	47.522.88	S 56 54	70	33.2427	47.524.27	S 42 73	54
33.1545	47.515.45	S 60 54	73	33.2216	47.522.16	S 55 28	69	33.2289	47.522.89	S 59 11	70	33.2428	47.524.28	S 42 74	54
33.1546	47.515.46	S 60 60	74	33.2217	47.522.17	S 55 29	69	33.2290	47.522.90	S5912	70	33.2429	47.524.29	S 42 75	54

1) Sign with the same message as IMPA and ISSA sign, but with a different format

IMPA and ISSA cross reference guide

IMPA	ISSA	Everlux	Page	IMPA	ISSA	Everlux	Page	IMPA	ISSA	Everlux	Page	IMPA	ISSA	Everlux	Page
33.2430	47.524.30	S 42 76	54	33.2896	47.528.96	S 42 40	56	33.4060	47.540.60	S 02 12	10	33.4127	47.541.27	S 02 76	11
33.2431	47.524.31	S 42 77	54	33.2974	47.529.74	S 42 41	56	33.4061	47.540.61	S 02 13	10	33.4129	47.541.29	S 02 77	11
33.2432	47.524.32	S 42 78	54	33.3014	47.530.14	S 40 71	52	33.4062	47.540.62	S 02 15	10	33.4130	47.541.30	S 03 46	12 ¹
33.2433	47.524.33	S 42 79	54	33.3100	47.531.00	S 40 51	52	33.4063	47.540.63	S 02 23	10	33.4131	47.541.31	S 02 78	11
33.2434	47.524.34	S 42 80	54	33.3101	47.531.01	S 40 52	52	33.4064	47.540.64	S 02 19	10	33.4132	47.541.32	S 02 84	11
33.2435	47.524.35	S 42 81	54	33.3102	47.531.02	S 40 53	52	33.4065	47.540.65	S 02 20	10	33.4133	47.541.33	S 02 85	11
33.2436	47.524.36	S 42 82	54	33.3103	47.531.03	S 40 54	52	33.4066	47.540.66	S 02 18	10	33.4134	47.541.34	S 02 61	11
33.2437	47.524.37	S 42 83	54	33.3104	47.531.04	S 40 58	52	33.4067	47.540.67	S 02 21	10	33.4135	47.541.35	S 03 10	12
33.2438	47.524.38	S 42 84	54	33.3105	47.531.05	S 40 59	52	33.4068	47.540.68	S 02 22	10	33.4136	47.541.36	S 03 37	12
33.2439	47.524.39	S 42 85	54	33.3106	47.531.06	S 40 60	52	33.4069	47.540.69	S 03 61	13	33.4137	47.541.37	S 03 02	12
33.2440	47.524.40	S 42 86	54	33.3108	47.531.08	S 40 81	53	33.4070	47.540.70	S 02 24	10	33.4138	47.541.38	S 03 31	12
33.2441	47.524.41	S 42 87	54	33.3109	47.531.09	S 40 55	52	33.4071	47.540.71	S 02 25	10	33.4139	47.541.39	S 03 11	12
33.2442	47.524.42	S 42 88	54	33.3110	47.531.10	S 40 61	52	33.4075	47.540.75	S 02 16	10	33.4140	47.541.40	S 03 40	12
33.2443	47.524.43	S 42 89	54	33.3111	47.531.11	S 41 04	53	33.4076	47.540.76	S 02 17	10	33.4141	47.541.41	S 03 63	13
33.2501	47.525.01	S 47 01	64	33.3112	47.531.12	S 40 56	52	33.4078	47.540.78	S 02 27	10	33.4142	47.541.42	S 02 64	11
33.2502	47.525.02	S 47 02	64	33.3113	47.531.13	S 40 62	52	33.4080	47.540.80	S 02 14	10	33.4150	47.541.50	S 02 26	10
33.2503	47.525.03	S 47 03	64	33.3114	47.531.14	S 40 63	52	33.4081	47.540.81	S 14 66	11	33.4151	47.541.51	S 03 04	12
33.2504	47.525.04	S 47 04	64	33.3115	47.531.15	S 40 64	52	33.4101	47.541.01	S 02 52	11	33.4152	47.541.52	S 03 03	12
33.2506	47.525.06	S 47 05	64	33.3116	47.531.16	S 40 57	52	33.4102	47.541.02	S 02 53	11	33.4153	47.541.53	S 02 28	10
33.2507	47.525.07	S 47 06	64	33.3122	47.531.22	S 41 01	53	33.4103	47.541.03	S 02 54	11	33.4154	47.541.54	S 03 14	12
33.2508	47.525.08	S 47 07	64	33.3123	47.531.23	S 41 02	53	33.4104	47.541.04	S 02 55	11	33.4155	47.541.55	S 03 13	12
33.2509	47.525.09	S 47 08	64	33.3124	47.531.24	S 41 03	53	33.4105	47.541.05	S 02 56	11	33.4157	47.541.57	S 14 65	11
33.2510	47.525.10	S 47 09	64	33.3125	47.531.25	S 41 05	53	33.4106	47.541.06	S 02 57	11	33.4170	47.541.70	S 03 21	12 ¹
33.2520	47.525.20	S 47 55	64	33.3126	47.531.26	S 41 06	53	33.4107	47.541.07	S 02 58	11	33.4171	47.541.71	S 03 38	12
33.2521	47.525.21	S 47 54	64	33.3127	47.531.27	S 41 08	53	33.4108	47.541.08	S 02 59	11	33.4172	47.541.72	S 03 34	12
33.2522	47.525.22	S 47 53	64	33.3128	47.531.28	S 41 09	53	33.4109	47.541.09	S 02 60	11	33.4173	47.541.73	S 03 39	12
33.2523	47.525.23	S 47 52	64	33.3129	47.531.29	S 41 10	53	33.4110	47.541.10	S 02 62	11	33.4174	47.541.74	S 03 49	12
33.2524	47.525.24	S 47 51	64	33.3135	47.531.35	S 41 11	53	33.4111	47.541.11	S 02 63	11	33.4175	47.541.75	S 03 50	12
33.2525	47.525.25	S 47 56	64	33.3136	47.531.36	S 41 12	53	33.4112	47.541.12	S 02 65	11	33.4176	47.541.76	S 03 33	12
33.2526	47.525.26	S 47 57	64	33.3137	47.531.37	S 41 13	53	33.4113	47.541.13	S 02 73	11	33.4177	47.541.77	S 03 32	12
33.2527	47.525.27	S 47 59	64	33.3138	47.531.38	S 40 72	52	33.4114	47.541.14	S 02 69	11	33.4178	47.541.78	S 03 45	12
33.2528	47.525.28	S 47 58	64	33.3139	47.531.39	S 40 73	52	33.4115	47.541.15	S 02 70	11	33.4179	47.541.79	S 03 42	12
33.2529	47.525.29	S 47 60	64	33.4050	47.540.50	S 02 01	10	33.4116	47.541.16	S 02 68	11	33.4180	47.541.80	S 03 44	12
33.2530	47.525.30	S 47 61	64	33.4051	47.540.51	S 02 02	10	33.4117	47.541.17	S 02 71	11	33.4181	47.541.81	S 03 53	12
33.2531	47.525.31	S 47 62	64	33.4052	47.540.52	S 02 03	10	33.4118	47.541.18	S 02 72	11	33.4182	47.541.82	S 03 48	12
33.2532	47.525.32	S 47 63	64	33.4053	47.540.53	S 02 04	10	33.4119	47.541.19	S 03 62	13	33.4183	47.541.83	S 03 51	12
33.2540	47.525.40	S 47 81	64	33.4054	47.540.54	S 02 05	10	33.4120	47.541.20	S 02 74	11	33.4184	47.541.84	S 03 52	12
33.2541	47.525.41	S 47 10	64	33.4055	47.540.55	S 02 06	10	33.4121	47.541.21	S 02 75	11	33.4187	47.541.87	S 05 51	16
33.2542	47.525.42	S 47 11	64	33.4056	47.540.56	S 02 07	10	33.4123	47.541.23	S 02 51	11	33.4188	47.541.88	S 03 43	12
33.2703	47.527.03	S 42 10	55 ¹	33.4057	47.540.57	S 02 08	10	33.4124	47.541.24	S 03 62	13	33.4189	47.541.89	S 03 47	12
33.2760	47.527.60	S 32 92	42	33.4058	47.540.58	S 02 09	10	33.4125	47.541.25	S 02 66	11	33.4193	47.541.93	S 03 41	12
33.2889	47.528.89	S 42 42	56	33.4059	47.540.59	S 02 10	10	33.4126	47.541.26	S 02 67	11	33.4200	47.542.00	S 04 00	14

1) Sign with the same message as IMPA and ISSA sign, but with a different format

IMPA and ISSA cross reference guide

IMPA	ISSA	Everlux	Page	IMPA	ISSA	Everlux	Page	IMPA	ISSA	Everlux	Page	IMPA	ISSA	Everlux	Page
33.4201	47.542.01	S 04 01	14	33.4321	47.543.21	S 03 87	13	33.4425	47.544.25	S 04 63	15	33.5678	47.556.78	S 35 69	45
33.4202	47.542.02	S 04 02	14	33.4322	47.543.22	S 03 85	13	33.4426	47.544.26	S 04 10	14 ¹	33.5679	47.556.79	S 36 16	46
33.4203	47.542.03	S 04 03	14	33.4323	47.543.23	S 03 88	13	33.4427	47.544.27	S 04 10	14	33.5680	47.556.80	S 36 84	47
33.4204	47.542.04	S 04 04	14	33.4324	47.543.24	S 03 84	13	33.4454	47.544.54	S 03 66	15	33.5690	47.556.90	S 36 48	47
33.4205	47.542.05	S 04 05	14	33.4325	47.543.25	S 03 79	13	33.4455	47.544.55	S 03 67	15	33.5691	47.556.91	S 36 49	47
33.4206	47.542.06	S 04 06	14	33.4326	47.543.26	S 03 83	13	33.4470	47.544.70	S 04 15	14	33.5692	47.556.92	S 36 50	47
33.4207	47.542.07	S 04 07	14	33.4327	47.543.27	S 03 80	13	33.4471	47.544.71	S 04 16	14	33.5693	47.556.93	S 36 52	47
33.4208	47.542.08	S 04 08	14	33.4328	47.543.28	S 03 82	13	33.4480	47.544.80	S 05 18	16	33.5694	47.556.94	S 36 53	47
33.4209	47.542.09	S 04 09	14	33.4329	47.543.29	S 03 81	13	33.4481	47.544.81	S 05 19	16	33.5695	47.556.95	S 36 54	47
33.4210	47.542.10	S 04 1A	14	33.4331	47.543.31	S 03 77	13	33.4482	47.544.82	S 05 15	16	33.5696	47.556.96	S 36 51	47
33.4211	47.542.11	S 04 1B	14	33.4332	47.543.32	S 03 76	13	33.4483	47.544.83	S 05 16	16	33.5709	47.557.09	S 35 67	45
33.4212	47.542.12	S 04 1C	14	33.4333	47.543.33	S 03 78	13	33.4820	47.548.20	S 04 71	15	33.5710	47.557.10	S 35 51	45 ¹
33.4213	47.542.13	S 04 1D	14	33.4334	47.543.34	S 03 75	13	33.4821	47.548.21	S 04 93	15	33.5712	47.557.12	S 35 53	45 ¹
33.4214	47.542.14	S 04 1E	14	33.4335	47.543.35	S 03 71	13	33.4824	47.548.24	S 04 85	15	33.5716	47.557.16	S 35 73	45 ¹
33.4215	47.542.15	S 04 1F	14	33.4336	47.543.36	S 03 74	13	33.4825	47.548.25	S 04 81	15	33.5719	47.557.19	S 35 68	45
33.4240	47.542.40	S 04 00	14	33.4337	47.543.37	S 03 72	13	33.5100	47.551.00	S 01 01	9	33.5721	47.557.21	S 35 62	45
33.4241	47.542.41	S 04 01	14	33.4339	47.543.39	S 03 73	15	33.5101	47.551.01	S 01 02	9	33.5722	47.557.22	S 35 63	45
33.4242	47.542.42	S 04 02	14	33.4340	47.543.40	S 04 55	14	33.5102	47.551.02	S 01 03	9	33.5723	47.557.23	S 35 55	45 ¹
33.4243	47.542.43	S 04 03	14	33.4341	47.543.41	S 04 56	15	33.5103	47.551.03	S 01 04	9	33.5724	47.557.24	S 35 65	45 ¹
33.4244	47.542.44	S 04 04	14	33.4342	47.543.42	S 04 54	15	33.5104	47.551.04	S 01 05	9	33.5725	47.557.25	S 35 70	45
33.4245	47.542.45	S 04 05	14	33.4343	47.543.43	S 04 52	15	33.5105	47.551.05	S 01 06	9	33.5726	47.557.26	S 35 76	45 ¹
33.4246	47.542.46	S 04 06	14	33.4344	47.543.44	S 04 53	15	33.5106	47.551.06	S 01 07	9	33.5727	47.557.27	S 35 66	45 ¹
33.4247	47.542.47	S 04 07	14	33.4345	47.543.45	S 04 51	15	33.5107	47.551.07	S 01 08	9	33.5728	47.557.28	S 35 71	45 ¹
33.4248	47.542.48	S 04 08	14	33.4400	47.544.00	S 04 42	15	33.5108	47.551.08	S 01 09	9	33.5729	47.557.29	S 35 92	46 ¹
33.4249	47.542.49	S 04 09	14	33.4401	47.544.01	S 04 43	15	33.5109	47.551.09	S 01 10	9	33.5731	47.557.31	S 35 64	45 ¹
33.4250	47.542.50	S 04 1A	14	33.4402	47.544.02	S 04 41	15	33.5641	47.556.41	S 34 36	43	33.5733	47.557.33	S 35 52	45 ¹
33.4251	47.542.51	S 04 1B	14	33.4403	47.544.03	S 04 44	15	33.5642	47.556.42	S 35 01	44	33.5734	47.557.34	S 35 54	45 ¹
33.4252	47.542.52	S 04 1C	14	33.4404	47.544.04	S 04 40	15	33.5643	47.556.43	S 35 24	44	33.5735	47.557.35	S 35 91	46
33.4253	47.542.53	S 04 1D	14	33.4405	47.544.05	S 04 35	15	33.5644	47.556.44	S 35 02	44	33.5736	47.557.36	S 36 46	47 ¹
33.4254	47.542.54	S 04 1E	14	33.4406	47.544.06	S 04 39	15	33.5645	47.556.45	S 35 12	44	33.5737	47.557.37	S 36 42	47 ¹
33.4255	47.542.55	S 04 1F	14	33.4407	47.544.07	S 04 36	15	33.5646	47.556.46	S 35 05	44	33.5738	47.557.38	S 36 43	47 ¹
33.4300	47.543.00	S 03 96	13	33.4408	47.544.08	S 04 38	15	33.5647	47.556.47	S 35 04	44	33.5739	47.557.39	S 36 44	47 ¹
33.4301	47.543.01	S 03 97	13	33.4409	47.544.09	S 04 37	15	33.5648	47.556.48	S 35 03	44	33.5740	47.557.40	S 36 45	47 ¹
33.4302	47.543.02	S 03 95	13	33.4410	47.544.10	S 04 46	15	33.5649	47.556.49	S 35 06	44	33.5745	47.557.45	S 36 55	47
33.4303	47.543.03	S 03 98	13	33.4411	47.544.11	S 04 45	15	33.5650	47.556.50	S 35 07	44	33.5746	47.557.46	S 36 56	47
33.4304	47.543.04	S 03 94	13	33.4413	47.544.13	S 04 47	15	33.5651	47.556.51	S 35 15	44	33.5747	47.557.47	S 40 01	51
33.4305	47.543.05	S 03 89	13	33.4416	47.544.16	S 04 48	15	33.5652	47.556.52	S 35 14	44	33.5748	47.557.48	S 36 57	47
33.4306	47.543.06	S 03 93	13	33.4420	47.544.20	S 03 64	13	33.5653	47.556.53	S 35 11	44	33.5750	47.557.50	S3658	47
33.4307	47.543.07	S 03 90	13	33.4421	47.544.21	S 03 65	13	33.5654	47.556.54	S 35 08	44	33.5751	47.557.51	S 36 59	47
33.4308	47.543.08	S 03 92	13	33.4422	47.544.22	S 04 61	15	33.5655	47.556.55	S 35 21	44	33.5752	47.557.52	S 36 60	47
33.4309	47.543.09	S 03 91	13	33.4423	47.544.23	S 04 62	15	33.5656	47.556.56	S 00 11	9	33.5753	47.557.53	S 36 61	47
33.4320	47.543.20	S 03 86	13	33.4424	47.544.24	S 04 65	15	33.5675	47.556.75	S 35 91	46	33.5754	47.557.54	S 36 62	47

1) Sign with the same message as IMPA and ISSA sign, but with a different format

IMPA and ISSA cross reference guide

IMPA	ISSA	Everlux	Page	IMPA	ISSA	Everlux	Page	IMPA	ISSA	Everlux	Page	IMPA	ISSA	Everlux	Page
33.5755	47.557.55	S 36 63	47	33.5903	47.559.03	S 61 06	75	33.6042	47.560.42	S 10 80	19	33.6082	47.560.82	S 10 46	18
33.5756	47.557.56	S 36 64	47	33.6001	47.560.01	S 10 01	17	33.6043	47.560.43	S 10 07	17	33.6083	47.560.83	S 10 47	18
33.5768	47.557.68	S 36 47	47 ¹	33.6002	47.560.02	S 10 02	17	33.6043	47.560.43	S 13 10	22	33.6084	47.560.84	S 10 48	18
33.5769	47.557.69	S 36 83	47 ¹	33.6003	47.560.03	S 10 03	17	33.6044	47.560.44	S 10 08	17	33.6085	47.560.85	S 10 49	18
33.5782	47.557.82	S 35 77	45 ¹	33.6004	47.560.04	S 10 04	17	33.6045	47.560.45	S 10 09	17	33.6086	47.560.86	S 10 50	18
33.5800	47.558.00	S 34 21	43	33.6005	47.560.05	S 10 05	17	33.6046	47.560.46	S 10 11	17	33.6087	47.560.87	S 14 55	23
33.5801	47.558.01	S 34 31	43	33.6006	47.560.06	S 10 06	17	33.6047	47.560.47	S 10 10	17	33.6088	47.560.88	S 14 58	23
33.5802	47.558.02	S 34 20	43	33.6007	47.560.07	S 10 13	17	33.6048	47.560.48	S 10 12	17	33.6089	47.560.89	S 14 57	23
33.5803	47.558.03	S 34 08	43	33.6008	47.560.08	S 10 14	17	33.6049	47.560.49	S 10 19	17	33.6091	47.560.91	S 14 56	23
33.5804	47.558.04	S 34 07	43	33.6009	47.560.09	S 10 15	17	33.6050	47.560.50	S 10 20	17	33.6100	47.561.00	S 16 01	24
33.5805	47.558.05	S 34 09	43	33.6010	47.560.10	S 10 16	17	33.6051	47.560.51	S 10 21	17	33.6101	47.561.01	S 13 12	22
33.5806	47.558.06	S 34 35	43	33.6011	47.560.11	S 10 17	17	33.6052	47.560.52	S 10 22	17	33.6102	47.561.02	S 16 06	24
33.5807	47.558.07	S 34 13	43	33.6012	47.560.12	S 10 18	17	33.6053	47.560.53	S 10 23	17	33.6103	47.561.03	S 18 05	27
33.5808	47.558.08	S 34 02	43	33.6013	47.560.13	S 10 25	17	33.6054	47.560.54	S 10 24	17	33.6104	47.561.04	S 18 06	27
33.5809	47.558.09	S 34 29	43	33.6014	47.560.14	S 10 26	17	33.6055	47.560.55	S 10 84	19	33.6120	47.561.20	S 16 72	25
33.5811	47.558.11	S 34 15	43	33.6015	47.560.15	S 10 27	17	33.6056	47.560.56	S 10 81	19	33.6121	47.561.21	S 18 23	27
33.5812	47.558.12	S 34 18	43	33.6016	47.560.16	S 10 28	17	33.6056	47.560.56	S 13 13	22	33.6122	47.561.22	S 16 75	25
33.5814	47.558.14	S 34 14	43	33.6017	47.560.17	S 10 29	17	33.6057	47.560.57	S 10 41	18	33.6123	47.561.23	S 18 21	27
33.5817	47.558.17	S 34 01	43	33.6018	47.560.18	S 10 30	17	33.6058	47.560.58	S 10 31	17	33.6124	47.561.24	S 18 22	27
33.5818	47.538.18	S 34 04	43	33.6019	47.560.19	S 10 34	18	33.6059	47.560.59	S 10 32	17	33.6140	47.561.40	S 19 01	28
33.5819	47.538.19	S 34 05	43	33.6020	47.560.20	S 10 35	18	33.6060	47.560.60	S 10 33	18	33.6141	47.561.41	S 19 10	28
33.5820	47.538.20	S 34 06	43	33.6021	47.560.21	S 10 36	18	33.6061	47.560.61	S 10 82	19	33.6142	47.561.42	S 19 11	28
33.5822	47.558.22	S 34 38	43	33.6022	47.560.22	S 10 37	18	33.6062	47.560.62	S 10 83	19	33.6143	47.561.43	S 19 12	28
33.5824	47.558.24	S 36 01	46	33.6023	47.560.23	S 10 38	18	33.6063	47.560.63	S 10 51	18	33.6144	47.561.44	S 19 06	28
33.5825	47.558.25	S 36 03	46	33.6024	47.560.24	S 10 39	18	33.6064	47.560.64	S 10 61	18	33.6145	47.561.45	S 19 07	28
33.5851	47.558.51	S 36 17	46	33.6025	47.560.25	S 10 85	19	33.6065	47.560.65	S 10 62	18	33.6146	47.561.46	S 19 09	28
33.5852	47.558.52	S 36 18	46	33.6026	47.560.26	S 10 86	19	33.6066	47.560.66	S 10 63	18	33.6147	47.561.47	S 19 13	28
33.5853	47.558.53	S 36 19	46	33.6027	47.560.27	S 10 40	18	33.6067	47.560.67	S 10 53	18	33.6148	47.561.48	S1914	28
33.5855	47.558.55	S 36 02	46	33.6028	47.560.28	S 10 58	18	33.6068	47.560.68	S 10 54	18	33.6149	47.561.49	S 19 23	28
33.5870	47.558.70	S 36 07	46 ¹	33.6029	47.560.29	S 10 42	18	33.6069	47.560.69	S 10 55	18	33.6150	47.561.50	S 19 34	28
33.5871	47.558.71	S 36 08	46 ¹	33.6030	47.560.30	S 10 52	18	33.6070	47.560.70	S 10 56	18	33.6151	47.561.51	S 19 24	28
33.5872	47.558.72	S 36 20	46 ¹	33.6031	47.560.31	S 10 59	18	33.6071	47.560.71	S 10 57	18	33.6152	47.561.52	S 19 18	28
33.5873	47.558.73	S 36 13	46 ¹	33.6032	47.560.32	S 10 69	18	33.6072	47.560.72	S 10 77	19	33.6153	47.561.53	S 19 19	28
33.5874	47.558.74	S 36 14	46 ¹	33.6033	47.560.33	S 10 71	18	33.6073	47.560.73	S 10 65	18	33.6154	47.561.54	S 19 20	28
33.5875	47.558.75	S 36 21	46 ¹	33.6034	47.560.34	S 10 70	18	33.6074	47.560.74	S 10 66	18	33.6155	47.561.55	S 19 21	28
33.5876	47.558.76	S 36 11	46 ¹	33.6035	47.560.35	S 10 72	18	33.6075	47.560.75	S 10 67	18	33.6157	47.561.57	S 19 29	28
33.5877	47.558.77	S 36 81	47 ¹	33.6036	47.560.36	S 10 64	18	33.6076	47.560.76	S 10 68	18	33.6158	47.561.58	S 19 22	28
33.5878	47.558.78	S 36 82	47 ¹	33.6037	47.560.37	S 10 60	18	33.6077	47.560.77	S 10 78	19	33.6159	47.561.59	S 19 28	28
33.5881	47.558.81	S3612	46	33.6038	47.560.38	S 10 73	18	33.6078	47.560.78	S 10 79	19	33.6160	47.561.60	S 19 26	28
33.5900	47.559.00	S 61 04	75	33.6039	47.560.39	S 10 75	19	33.6079	47.560.79	S 10 43	18	33.6163	47.561.63	S 19 03	28
33.5901	47.559.01	S 61 05	75	33.6040	47.560.40	S 10 74	18	33.6080	47.560.80	S 10 44	18	33.6164	47.561.64	S 19 05	28
33.5902	47.559.02	S 61 03	75	33.6041	47.560.41	S 10 76	19	33.6081	47.560.81	S 10 45	18	33.6165	47.561.65	S 19 04	28

1) Sign with the same message as IMPA and ISSA sign, but with a different format

IMPA and ISSA cross reference guide

IMPA	ISSA	Everlux	Page	IMPA	ISSA	Everlux	Page	IMPA	ISSA	Everlux	Page	IMPA	ISSA	Everlux	Page
33.6200	47.562.00	S 1970	25	33.6760	47.567.60	S 12 10	19	33.6805	47.568.05	S 12 55	20	33.6850	47.568.50	S 13 87	23
33.6201	47.562.01	S 19 61	25	33.6761	47.567.61	S 12 11	19	33.6806	47.568.06	S 12 56	20	33.6851	47.568.51	S 13 89	23
33.6202	47.562.02	S 19 62	25	33.6762	47.567.62	S 12 12	19	33.6807	47.568.07	S 12 57	20	33.6853	47.568.53	S 13 86	23
33.6203	47.562.03	S 19 63	25	33.6763	47.567.63	S 12 13	19	33.6808	47.568.08	S 12 58	20	33.6854	47.568.54	S 13 84	23
33.6204	47.562.04	S 19 64	25	33.6764	47.567.64	S 12 14	19	33.6809	47.568.09	S 12 59	20	33.6855	47.568.55	S 13 88	23
33.6205	47.562.05	S 19 65	25	33.6765	47.567.65	S 12 15	19	33.6810	47.568.10	S 12 61	20	33.6856	47.568.56	S 13 90	23
33.6206	47.562.06	S 19 66	25	33.6766	47.567.66	S 12 16	19	33.6811	47.568.11	S 12 60	20	33.6857	47.568.57	S 12 97	21
33.6207	47.562.07	S 19 67	25	33.6767	47.567.67	S 12 17	19	33.6812	47.568.12	S 12 62	20	33.6858	47.568.58	S 12 98	21
33.6208	47.562.08	S 19 68	25	33.6768	47.567.68	S 12 18	19	33.6813	47.568.13	S 12 63	21	33.6859	47.568.59	S 12 99	21
33.6209	47.562.09	S 19 69	25	33.6769	47.567.69	S 12 19	19	33.6815	47.568.15	S 12 65	21	33.6860	47.568.60	S 13 01	21
33.6210	47.562.10	S 16 10	24	33.6770	47.567.70	S 12 20	19	33.6816	47.568.16	S 12 69	21	33.6861	47.568.61	S 13 00	21
33.6211	47.562.11	S 16 09	24	33.6771	47.567.71	S 12 21	19	33.6817	47.568.17	S 12 68	21	33.6862	47.568.62	S 13 02	21
33.6250	47.562.50	S 1970	25	33.6772	47.567.72	S 12 22	19	33.6818	47.568.18	S 12 66	21	33.6863	47.568.63	S 13 03	21
33.6251	47.562.51	S 1961	25	33.6773	47.567.73	S 12 23	19	33.6819	47.568.19	S 12 67	21	33.6864	47.568.64	S 13 04	21
33.6252	47.562.52	S 1962	25	33.6774	47.567.74	S 12 24	19	33.6820	47.568.20	S 12 70	21	33.6867	47.568.67	S 13 07	22
33.6253	47.562.53	S 1963	25	33.6775	47.567.75	S 12 25	19	33.6821	47.568.21	S 12 71	21	33.6869	47.568.69	S 13 09	22
33.6254	47.562.54	S 1964	25	33.6776	47.567.76	S 12 26	19	33.6822	47.568.22	S 12 73	21	33.6872	47.568.72	S 13 12	22
33.6255	47.562.55	S 1965	25	33.6777	47.567.77	S 12 27	20	33.6823	47.568.23	S 12 72	21	33.6875	47.568.75	S 13 15	22
33.6256	47.562.56	S 1966	25	33.6778	47.567.78	S 12 28	20	33.6824	47.568.24	S 12 74	21	33.6876	47.568.76	S 10 83	19
33.6257	47.562.57	S 1967	25	33.6779	47.567.79	S 12 29	20	33.6825	47.568.25	S 12 75	21	33.7000	47.570.00	S 32 71	42
33.6258	47.562.58	S 1968	25	33.6780	47.567.80	S 12 30	20	33.6826	47.568.26	S 12 76	21	33.7500	47.575.00	S 30 01	40 ¹
33.6259	47.562.59	S 1969	25	33.6781	47.567.81	S 12 31	20	33.6827	47.568.27	S 12 77	21	33.7501	47.575.01	S 30 06	40 ¹
33.6300	47.563.00	S 18 48	27	33.6782	47.567.82	S 12 32	20	33.6828	47.568.28	S 12 79	21	33.7502	47.575.02	S 30 12	40 ¹
33.6301	47.563.01	S 16 85	24	33.6783	47.567.83	S 12 33	20	33.6829	47.568.29	S 12 78	21	33.7503	47.575.03	S 30 09	40 ¹
33.6500	47.565.00	S 25 71	38	33.6784	47.567.84	S 12 34	20	33.6830	47.568.30	S 12 80	21	33.7504	47.575.04	S 30 03	40 ¹
33.6501	47.565.01	S 25 11	38	33.6785	47.567.85	S 12 35	20	33.6831	47.568.31	S 12 81	21	33.7505	47.575.05	S 31 04	41 ¹
33.6502	47.565.02	S 25 73	38	33.6786	47.567.86	S 12 36	20	33.6832	47.568.32	S 12 82	21	33.7506	47.575.06	S 31 03	41 ¹
33.6503	47.565.03	S 25 17	38	33.6787	47.567.87	S 12 37	20	33.6833	47.568.33	S 12 83	21	33.7507	47.575.07	S 31 01	41 ¹
33.6504	47.565.04	S 25 72	38	33.6788	47.567.88	S 12 38	20	33.6834	47.568.34	S 12 85	21	33.7508	47.575.08	S 30 07	40 ¹
33.6505	47.565.05	S 25 15	38	33.6789	47.567.89	S 12 39	20	33.6835	47.568.35	S 12 84	21	33.7509	47.575.09	S 31 02	41 ¹
33.6506	47.565.06	S 25 74	38	33.6790	47.567.90	S 12 40	20	33.6836	47.568.36	S 12 86	21	33.7510	47.575.10	S 31 07	41 ¹
33.6507	47.565.07	S 25 19	38	33.6791	47.567.91	S 12 41	20	33.6837	47.568.37	S 12 87	21	33.7511	47.575.11	S 31 10	41 ¹
33.6715	47.567.15	S 14 51	23	33.6792	47.567.92	S 12 42	20	33.6838	47.568.38	S 12 88	21	33.7514	47.575.14	S 31 09	41
33.6751	47.567.51	S 12 01	19	33.6793	47.567.93	S 12 43	20	33.6841	47.568.41	S 12 91	21	33.7515	47.575.15	S 31 12	41 ¹
33.6752	47.567.52	S 12 02	19	33.6794	47.567.94	S 12 44	20	33.6842	47.568.42	S 12 92	21	33.7516	47.575.16	S 30 02	40 ¹
33.6753	47.567.53	S 12 03	19	33.6795	47.567.95	S 12 45	20	33.6843	47.568.43	S 12 93	21	33.7540	47.575.40	S 30 51	40 ¹
33.6754	47.567.54	S 12 04	19	33.6797	47.567.97	S 12 47	20	33.6844	47.568.44	S 12 94	21	33.7541	47.575.41	S 32 15	42 ¹
33.6755	47.567.55	S 12 05	19	33.6799	47.567.99	S 12 49	20	33.6845	47.568.45	S 12 95	21	33.7542	47.575.42	S 30 52	40 ¹
33.6756	47.567.56	S 12 06	19	33.6801	47.568.01	S 12 51	20	33.6846	47.568.46	S 12 96	21	33.7543	47.575.43	S 30 53	40 ¹
33.6757	47.567.57	S 12 07	19	33.6802	47.568.02	S 12 52	20	33.6847	47.568.47	S 13 82	23	33.7544	47.575.44	S 30 54	40 ¹
33.6758	47.567.58	S 12 08	19	33.6803	47.568.03	S 12 53	20	33.6848	47.568.48	S 13 85	23	33.7545	47.575.45	S 30 55	40 ¹
33.6759	47.567.59	S 12 09	19	33.6804	47.568.04	S 12 54	20	33.6849	47.568.49	S 13 83	23	33.7546	47.575.46	S 30 56	40 ¹

1) Sign with the same message as IMPA and ISSA sign, but with a different format

IMPA and ISSA cross reference guide



IMPA	ISSA	Everlux	Page	IMPA	ISSA	Everlux	Page	IMPA	ISSA	Everlux	Page	IMPA	ISSA	Everlux	Page
33.7547	47.575.47	S 30 57	40 ¹	33.7613	47.576.13	S 31 53	41 ¹	33.8505	47.585.05	S 39 02	48	33.8566	47.585.66	S 39 66	50
33.7548	47.575.48	S 30 58	40 ¹	33.7614	47.576.14	S 31 60	41 ¹	33.8506	47.585.06	S 38 07	48	33.8567	47.585.67	S 39 68	50
33.7549	47.575.49	S 30 61	40 ¹	33.7615	47.576.15	S 31 59	41 ¹	33.8508	47.585.08	S 38 10	48	33.8568	47.585.68	S 39 55	50
33.7550	47.575.50	S 30 62	40 ¹	33.7616	47.576.16	S 31 57	41 ¹	33.8509	47.585.09	S 39 01	48	33.8569	47.585.69	S 39 56	50
33.7551	47.575.51	S 30 63	40 ¹	33.7617	47.576.17	S 31 58	41 ¹	33.8510	47.585.10	S 39 08	48	33.8570	47.585.70	S 39 54	50
33.7554	47.575.54	S 30 64	40 ¹	33.7618	47.576.18	S 31 56	41 ¹	33.8511	47.585.11	S 39 13	48	33.8570	47.585.70	S 40 15	51
33.7555	47.575.55	S 30 65	40 ¹	33.7619	47.576.19	S 31 55	41 ¹	33.8520	47.585.20	S 40 14	51	33.8574	47.585.74	S 39 91	51
33.7557	47.575.57	S 30 66	40 ¹	33.7620	47.576.20	S 30 82	40 ¹	33.8522	47.585.22	S 40 65	52	33.8574	47.585.74	S 40 16	51
33.7560	47.575.60	S 30 67	40 ¹	33.7623	47.576.23	S 30 83	40 ¹	33.8530	47.585.30	S 38 51	49	33.8575	47.585.75	S 40 12	51
33.7561	47.575.61	S 30 68	40 ¹	33.7623	47.576.23	S 32 75	42 ¹	33.8530	47.585.30	S 40 11	51	33.8576	47.585.76	S 39 59	50
33.7566	47.575.66	S 30 59	40 ¹	33.7624	47.576.24	S 30 69	40 ¹	33.8531	47.585.31	S 38 52	49	33.8585	47.585.85	S3961	50
33.7567	47.575.67	S 30 60	40 ¹	33.7624	47.576.24	S 32 73	42 ¹	33.8532	47.585.32	S 38 53	49	33.8587	47.585.87	S3962	50
33.7569	47.575.69	S 30 71	40	33.7625	47.576.25	S 31 61	41 ¹	33.8532	47.585.32	S 40 13	51	33.5747	47.557.47	S 40 01	51
33.7570	47.575.70	S 30 85	40 ¹	33.7626	47.576.26	S 31 62	41 ¹	33.8533	47.585.33	S 38 54	49	33.8567	47.585.67	S 40 04	51
33.7572	47.575.72	S 30 79	40 ¹	33.7627	47.576.27	S 31 63	41 ¹	33.8534	47.585.34	S3873	49	33.8619	47.586.19	S 40 02	51
33.7572	47.575.72	S 32 72	42 ¹	33.7628	47.576.28	S 31 64	41 ¹	33.8536	47.585.36	S 38 55	49	33.8619	47.586.19	S 40 20	51
33.7573	47.575.73	S 30 80	40 ¹	33.7629	47.576.29	S 30 84	40 ¹	33.8537	47.585.37	S 38 56	49	33.8658	47.586.58	S3953	50
33.7573	47.575.73	S 32 76	42 ¹	33.7630	47.576.30	S 31 67	41 ¹	33.8539	47.585.39	S 38 57	49	33.8684	47.586.84	S3869	49
33.7574	47.575.74	S 30 81	40 ¹	33.7631	47.576.31	S 31 65	41 ¹	33.8540	47.585.40	S 38 59	49	33.8690	47.586.90	S 39 81	50
33.7574	47.575.74	S 32 74	42 ¹	33.7632	47.576.32	S 31 68	41 ¹	33.8541	47.585.41	S 38 67	49	33.8691	47.586.91	S 39 82	50
33.7577	47.575.77	S 32 56	42	33.7633	47.576.33	S 31 69	41 ¹	33.8542	47.585.42	S 38 62	49	33.8692	47.586.92	S 39 83	50
33.7578	47.575.78	S 32 16	42	33.7634	47.576.34	S 31 70	41 ¹	33.8543	47.585.43	S 38 58	49	33.8695	47.586.95	S 42 31	56
33.7579	47.575.79	S 30 70	40	33.7635	47.576.35	S 31 66	41 ¹	33.8544	47.585.44	S 38 66	49				
33.7580	47.575.80	S 30 73	40 ¹	33.7636	47.576.36	S 31 71	41 ¹	33.8545	47.585.45	S 38 64	49				
33.7581	47.575.81	S 30 74	40 ¹	33.7650	47.576.50	S 31 81	42 ¹	33.8546	47.585.46	S 38 65	49				
33.7582	47.575.82	S 30 75	40 ¹	33.7651	47.576.51	S 32 00	42 ¹	33.8547	47.585.47	S 39 95	51				
33.7583	47.575.83	S 30 76	40 ¹	33.7660	47.576.60	S 31 82	42 ¹	33.8548	47.585.48	S 38 70	49				
33.7584	47.575.84	S 30 77	40 ¹	33.7668	47.576.68	S 30 72	40 ¹	33.8549	47.585.49	S 38 63	49				
33.7585	47.575.85	S 30 78	40 ¹	33.7670	47.576.70	S 31 83	42 ¹	33.8550	47.585.50	S 39 52	50				
33.7586	47.575.86	S3176	41	33.7673	47.576.73	S 31 86	42 ¹	33.8550	47.585.50	S 40 17	51				
33.7587	47.575.87	S 31 54	41 ¹	33.7680	47.576.80	S 31 84	42 ¹	33.8551	47.585.51	S 39 58	50				
33.7590	47.575.90	S 31 77	41 ¹	33.7681	47.576.81	S 31 85	42 ¹	33.8552	47.585.52	S 39 57	50				
33.7591	47.575.91	S 31 78	41 ¹	33.7700	47.577.00	S 32 12	42	33.8553	47.585.53	S 38 71	49				
33.7596	47.575.96	S 31 79	41 ¹	33.7701	47.577.01	S 32 13	42	33.8555	47.585.55	S 39 60	50				
33.7597	47.575.97	S 31 80	41 ¹	33.8000	47.580.00	S 32 61	42	33.8556	47.585.56	S 39 67	50				
33.7598	47.575.98	S 32 58	42	33.8002	47.580.02	S4019	51	33.8557	47.585.57	S 38 60	49				
33.7600	47.576.00	S 31 72	41 ¹	33.8003	47.580.03	S4018	51	33.8559	47.585.59	S 38 61	49				
33.7601	47.576.01	S 31 73	41 ¹	33.8500	47.585.00	S 38 01	48	33.8560	47.585.60	S 39 63	50				
33.7604	47.576.04	S 31 74	41 ¹	33.8501	47.585.01	S 38 02	48	33.8561	47.585.61	S 39 64	50				
33.7605	47.576.05	S 31 75	41 ¹	33.8502	47.585.02	S 38 03	48	33.8563	47.585.63	S 39 51	50				
33.7610	47.576.10	S 31 51	41 ¹	33.8503	47.585.03	S 38 04	48	33.8564	47.585.64	S 38 72	49				
33.7611	47.576.11	S 31 52	41 ¹	33.8504	47.585.04	S 38 05	48	33.8565	47.585.65	S 39 65	50				

1) Sign with the same message as IMPA and ISSA sign, but with a different format

IMO regulations and applicable standards

IMO Resolution A.654(16) adopted on 19 October 1989	Graphical symbols for fire control plans
IMO Resolution A.752(18) adopted on 4 November 1993	Guidelines for the evaluation, testing and application of low-location lighting on passenger ships
IMO Resolution A.760(18) adopted on 4 November 1993	Symbols related to life-saving appliances and arrangements
IMO Resolution A.952(23) adopted on 5 December 2003	Graphical symbols for shipboard fire control plans
IMO Resolution A.1116(30) adopted on 5 December 2017	Escape Route Signs and Equipment Location Markings.
IMO Polar Code	Code for Ships Operating in Polar Waters
SOLAS Convention 2004 chapter II-2 Regulation 13.3.2.5	Construction – Fire protection, fire detection and fire extinction - Means of escape - Marking of escape routes
SOLAS Convention 2004 chapter II-2 Regulation 13.7.2.2	Construction – Fire protection, fire detection and fire extinction - Means of escape - Instruction for safe escape
SOLAS Convention 2004 chapter III-Regulation 9.2.3	Life-saving appliances and arrangements - Operating instructions
MARPOL Annex V, 2012 Revision	International Convention for the Prevention of Pollution from Ships
ISPS Code 2003 adopted on 12 December 2002	International Ship and Port Facility Code
ICAO and IMO document 9636	International signs to provide guidance to persons at airports and marine terminals
IMDG Code 2014 Edition	International Maritime Dangerous Goods (IMDG) Code
ISM Code 2014 Edition	International Safety Management (ISM) Code
European Directive 2014/90/EU	Directive marine equipment repealed Directive 96/98/EC
ISO 24409-1:2010	Ships and marine technology - Design, location and use of shipboard safety signs, safety related signs, safety notices and safety markings - Part 1: Design principles
ISO 24409-1:2014	Ships and marine technology - Design, location and use of shipboard safety signs, safety-related signs, safety notices and safety markings - Part 2: Catalogue
ISO 24409-3:2014	Ships and marine technology - Design, location, and use of shipboard safety signs, safety-related signs, safety notices and safety markings - Part 3: Code of practise
ISO 16069:2017	Graphical symbols - Safety signs - Safety way guidance systems (SWGS)
ISO 3864-1:2011	Graphical symbols -Safety colours and safety signs - Part 1: Design principles for safety signs and safety markings
ISO 3864-2:2016	Graphical symbols - Safety colours and safety signs -Part 2: Design principles for product safety labels
ISO 17631:2002	Ships and marine technology -Shipboard plans for fire protection, life-saving appliances and means of escape
ISO 15370:2010	Ships and marine technology -Low-location lighting (LLL) on passenger ships -Arrangement
ISO 14726:2008	Ships and marine technology - Identification colours for the content of piping systems
ISO 20712-1:2008	Water safety signs and beach safety flags - Part 1: Specifications for water safety signs used in workplaces and public areas
EN ISO 7010:2020	Graphical symbols - Safety colours and safety signs -Registered safety signs
DIN 67510-1:2009	Photoluminescent pigments and products - Part 1: Measurement and marking at the producer.
REG 13-36 (PYC) Passenger yacht code January 2016	The code of practice for yachts carrying 13 to 36 passengers pleasure and leisure sector
MCA LY3, 2014	The Large Commercial Yatch Code (LY3)
NORSOK STANDARD L-004, 2016	Piping fabrication, installation, flushing and testing
NORSOK STANDARD C-002, Edition 4, September 2015	Architectural components and equipment
NORSOK STANDARD S-001, Edition 5, June 2018	Technical safety
2009 MODU CODE	IMO Code for the Construction and Equipment of Mobile Offshore Drilling Units, 2009
GOST R 12.2.143-2009	Occupational safety standards system. Photoluminescent evacuation systems. Requirements and methods of test
GOST R 12.4.026-2001	Occupational safety standards system. Safety colours, safety signs and signal marking. Purpose and rules of application. General technical

Quality and Certification

The quality of  Everlux® and  Everlux®-LLL photoluminescent products is ensured throughout the entire manufacturing process, using the most advanced technology along with rigorous quality controls which use cutting edge testing methodology that observes **IMO Resolutions, DIN and ISO Standards.**

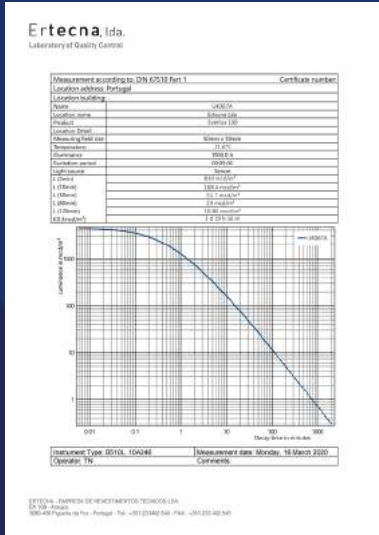

 Everlux® and  Everlux®-LLL are certified by:





Approval as Service Suppliers:



Our company certifications:



In accordance with legislation, standards and consumer protection, to ensure quality and conformity, our Trademarks are printed on  and  signs.



www.everluxmaritime.com

